



ORIGINAL SOLUTIONS. NO COMPROMISES.

INSTALLATION, OPERATION AND MAINTENANCE MANUAL		1 of 30
POLARIS - SERIES TBM 200 LH (8") - TYPE PHO / PBO / PVO		
DOCUMENT NBR. : A0455	REVISION: 2	EFFECTIVE DATE: 11-16-2014

POLARIS SERIES TBM 200 LH (8") TYPE PHO / PBO / PVO
ELECTRO-SUBMERSIBLE PUMP

PUMP TYPE: TBM 200 LH (8") TYPE ()

POLARIS PART NBR.: 700.200.05.

HP / V / Hz / Poles: / / /

INSULATION: F H
 EXPLOSION PROOF:
 CONTINUOUS IN AIR
 HIGH AMBIENT 90 Deg.C :
 LOW AMBIENT -25 Deg.C :

EQUIPMENT OPTIONS:

IMPELLER TRIM: () mm () in.

POWER CABLE: TOTAL (FEET)

INTERNAL SLURRY SEAL
 SLURRY BOSS
 SLURRY BOSS QUENCH RING
 LIGHT DUTY SLURRY SEAL
 SEAL GUARD

WATER JET RING
 WATER COOLING JACKET

COAL TAR EPOXY
 DUROMAR® EPOXY

PUMP SERIAL NUMBER: _____

DATE: _____

CUSTOMER: _____

CUSTOMER P.O. NBR. _____

SHIPPED TO: _____



ORIGINAL SOLUTIONS. NO COMPROMISES.

INSTALLATION, OPERATION AND MAINTENANCE MANUAL POLARIS - SERIES TBM 200 LH (8") - TYPE PHO / PBO / PVO	2 of 30	
DOCUMENT NBR. : A0455	REVISION: 2	EFFECTIVE DATE: 11-16-2014

TABLE OF CONTENTS

SECTION 1.0 INTRODUCTION

SECTION 2.0 WARRANTIES

SECTION 3.0 SAFETY

SECTION 4.0 MECHANICAL INSTALLATION

4.1 RECEIVING INSPECTION

4.2 STORAGE

4.2.1 NEW PUMP AND EQUIPMENT STORAGE

4.2.2 USED PUMP STORAGE

4.2.3 SPARE PARTS STORAGE

4.3 HANDLING

4.4 MECHANICAL SEAL INSPECTION

4.5 PUMP SET UP / MOUNTING

4.5.1 CABLE AND CHAIN SUSPENSION

4.5.2 OPTIONAL LIFTING / SUSPENSION BAIL MOUNTING

4.5.3 FLOOR MOUNTING

4.6 PIPING

4.6.1 DISCHARGE PIPING / DISCHARGE HOSE

4.6.2 PRIMARY SEAL FLUSH PIPING

4.6.3 OPTIONAL WATER JACKET / PIPING

4.6.4 OPTIONAL WATER JET RING

SECTION 5.0 ELECTRICAL INSTALLATION

5.1 GENERAL

5.2 MOISTURE DETECTION RELAY - THERMAL PROTECTION

5.3 INSTALLATION

**REFER TO THE BALDOR® - RELIANCE® ELECTRIC MOTOR
INSTALLATION & OPERATING MANUAL FOR
AC SUBMERSIBLE PUMP MOTORS – MN414 (SECTION 8.2)**

INSTALLATION, OPERATION AND MAINTENANCE MANUAL			3of 30
POLARIS - SERIES TBM 200 LH (8") - TYPE PHO / PBO / PVO			
DOCUMENT NBR. :	A0455	REVISION:	2
		EFFECTIVE DATE:	11-16-2014

SECTION 6.0 OPERATION

- 6.1 PRE START UP CHECK
- 6.2 PUMP START UP
- 6.3 PUMP SHUT DOWN
- 6.4 TROUBLE SHOOTING

SECTION 7.0 WET END INSTALLATION

- 7.1 TBM 200 LH - Type PHO - Open Suction, Strainer
- 7.2 TBM 200 LH - Type PBO - Open Suction, Strainer, Solids Mixer Attachment
- 7.3 TBM 200 LH - Type PVO - Open Suction, Strainer, Shredder Attachment

SECTION 8.0 APPENDIX

- 8.1 PUMP GENERAL ARRANGEMENT DRAWING, TBM 200 LH – PHO / PBO / PVO
 - 8.1.1 PUMP PERFORMANCE CURVE TYPE - PHO
 - 8.1.2 PUMP PERFORMANCE CURVE TYPE - PBO
 - 8.1.3 PUMP PERFORMANCE CURVE TYPE - PVO
- 8.2 BALDOR® - RELIANCE® ELECTRIC MOTOR
 INSTALLATION & OPERATION MANUAL FOR
 SUBMERSIBLE PUMP MOTORS – MN414
- 8.3 -
- 8.4 IMPELLER INSTALLATION / BOLT TORQUE REQUIREMENTS

INSTALLATION, OPERATION AND MAINTENANCE MANUAL			4 of 30
POLARIS - SERIES TBM 200 LH (8") - TYPE PHO / PBO / PVO			
DOCUMENT NBR. : A0455	REVISION: 2	EFFECTIVE DATE:	11-16-2014

1.0 INTRODUCTION

Your new **Series TBM** pump has been designed and manufactured to perform for many years with a minimum of maintenance. However, parts will wear and need replacing eventually. The period between maintenance will greatly depend on the service and your maintenance program.

Series TBM pumps are heavy duty submersible slurry pumps featuring motor armatures with a nominal service factor up to 2 depending on pump wet end and motor combination.

Pumps with standard F-Class motors are designed to operate submersed in slurry or other water based liquids with temperatures not exceeding 40°C (104°F). 60°C (140°F) temperatures and / or dry-running applications can be configured with an H-Class motor and / or an optional water jacket.

Special High Temp rated motors to 90°C (194°F) and 95°C (203°F) are available for hot sump applications. Special Low Temp rated motors to -25°C (-13°F) are also available.

A range of available motor seal options, starting with our continuous run dry capable internal slurry seal, can be combined with our motor and wet end options to configure a submersible pump package that can handle the most severe duties in applications across a broad spectrum of industries.

Motor modules of series TBM can be ordered in standard configuration or as explosion proof units per Class 1, Groups C&D, Temperature code T3C

UL Listed, File No. E10822

CSA Certified, File No. LR19467-15 (Frames 140,180,210,250 & 360)

CSA Certified, File No. LR19467-15 (Frame 320)

This manual has been compiled to help you minimize your maintenance and speed repairs when required. Read and understand this manual.

Please provide the Serial Number of your equipment if additional manuals are needed.

WHEN ORDERING PARTS ALWAYS REFER TO PUMP SERIAL NUMBER.
THIS NUMBER IS FOUND ON THE NAMEPLATE ON THE PUMP.



INSTALLATION, OPERATION AND MAINTENANCE MANUAL			5 of 30
POLARIS - SERIES TBM 200 LH (8") - TYPE PHO / PBO / PVO			
DOCUMENT NBR. : A0455	REVISION: 2	EFFECTIVE DATE:	11-16-2014

2.0 WARRANTIES

Seller warrants that the products covered by this contract conform to applicable drawings and specifications accepted in writing by Seller, will be free from defects in material and workmanship, will be merchantable and will perform in accordance with the detailed specifications accepted in writing by Seller.

These warranties extend for a period of twelve (12) months from the date of purchase by Buyer. Buyer's exclusive remedy and Seller's sole duty under these warranties is to repair or replace the product. Normal wear and tear on Seller's product shall not constitute a warranty defect.

THERE ARE NO OTHER WARRANTIES, EXPRESS OR IMPLIED, WHICH EXTEND BEYOND THOSE SET FORTH ABOVE. THE WARRANTY OF MERCHANTABILITY IS LIMITED TO THE PERIOD SPECIFIED ABOVE.

These warranties are contingent upon the product being stored, installed, maintained, and operated in accordance with good engineering practices and the instructions contained in the Operating and Maintenance Manual. Failure to do so shall operate to void all warranties. Seller's total responsibility for damages whether arising in contract or tort arising out of or relating to the performance of the product or the warranties hereunder shall be strictly limited to the contract price for the product. In no event shall Seller be liable for any incidental or consequential damages such as lost profits, loss of use of productive facilities or equipment, expenses or damages incurred in reliance on the product's performance or lost production whether suffered by buyer or any third party.

Seller warrants that the products comply with OSHA standards on drive guard design and construction (if applicable) in effect at the time of manufacture and makes no other warranty with respect to any other standards. Seller shall not be responsible for failure of parts to fit properly due to deterioration of or modification to Buyer's existing equipment for which such parts are furnished.

Seller makes no warranty or guarantee that the product supplied hereunder will comply with the performance of Buyer's existing equipment.

Seller reserves the right to furnish substitutes for material not available or whose use is restricted.

The use of (a) non-OEM components or (b) non-OEM pump spare parts and/or (c) non-approved modifications to the product and/or (d) failure to install a moisture detection relay and/or (e) failure to connect the thermal overload protection wiring will operate to void all warranties.

We reserve the right to change the design, construction or material of any part without incurring the obligation of installing such changes on pumps already delivered.

INSTALLATION, OPERATION AND MAINTENANCE MANUAL			6 of 30
POLARIS - SERIES TBM 200 LH (8") - TYPE PHO / PBO / PVO			
DOCUMENT NBR. :	A0455	REVISION:	2
		EFFECTIVE DATE:	11-16-2014

3.0 SAFETY

Do not install the equipment other than in accordance with the instructions contained in this manual.

When required information cannot be found in this manual, contact the nearest **POLARIS PUMPS** representative.

This instruction book should be read completely before starting installation, maintenance or operation. The equipment is capable of trouble free operation when properly installed, operated and maintained. These instructions present the basic information and methods required for proper installation and maintenance.

This pump has been designed to provide safe and reliable service, however as with all equipment of this type, the operator(s) must exercise good judgment and proper safety practices to avoid damage to the equipment and surroundings and to avoid personal injury. The instructions in this manual are intended for personnel with a general training in operation and maintenance of centrifugal pumps and electric motors.

It is assumed that your safety department has established a safety program based upon a thorough analysis of industrial hazards. Before installing, operating or performing maintenance on the pump and associated components described in this manual, it is suggested that the safety program be reviewed to ensure that it covers the hazards arising from rotating- and electrical machinery. In general, all personnel should be guided by all the basic rules of safety associated with the equipment and the process.

It should be understood that the information contained in this manual does not relieve operating and maintenance personnel of the responsibility of exercising normal good judgment in operation and care of the pump and its components.

INSTALLATION, OPERATION AND MAINTENANCE MANUAL			7 of 30
POLARIS - SERIES TBM 200 LH (8") - TYPE PHO / PBO / PVO			
DOCUMENT NBR. : A0455	REVISION: 2	EFFECTIVE DATE:	11-16-2014

4.0 INSTALLATION

4.1 RECEIVING INSPECTION

The unit must be inspected immediately upon arrival and any irregularities and damages due to shipment must be reported to the carrier and **POLARIS PUMPS**. A copy of this manual is included in the shipment. Put this manual a safe, accessible place for ready reference when required. It is important that the entire contents of this manual are studied before installation.

Pump parts and accessories may be packed inside shipping container, or attached to skids in individual packages. Inspect all containers, crates and skids before discarding.

4.2 STORAGE

4.2.1 NEW PUMP AND EQUIPMENT STORAGE

If your new pump is to be stored for a long period before use, the following procedures must be adhered to in order for **POLARIS PUMPS** to extend the normal warranties.

Notify **POLARIS PUMPS** that the equipment is to be stored and that the storage procedures will be followed. Notify **POLARIS PUMPS** when the equipment is to be removed from storage and put into service.

Failure to notify **POLARIS PUMPS** will result in your warranty being void. Your new pump will arrive ready for use. Close off all flush and cooling water inlet ports and cooling water exhaust ports on water jackets. Suitable covers out of plywood or plastic must be installed on the suction entrance and discharge to provide adequate protection against dirt, dust and nesting animals. The main power and control cable ends must be protected by means of suitable shrink-on boots or similar to prevent the ingress of moisture during storage.

Equipment should be stored in a dry location and situated on an even surface with no strains applied. If stored outdoors, the equipment must be covered with a waterproof tarp secured to the equipment or skid.

INSTALLATION, OPERATION AND MAINTENANCE MANUAL			8 of 30
POLARIS - SERIES TBM 200 LH (8") - TYPE PHO / PBO / PVO			
DOCUMENT NBR. : A0455	REVISION: 2	EFFECTIVE DATE:	11-16-2014

4.2.2 USED PUMP STORAGE

A used pump should be completely disassembled and all parts cleaned and inspected. All unpainted metal surfaces should be coated with grease or suitable protectant. All previously painted parts should be touched up or repainted. Reassemble the pump as per Sections 7.0 and store as per Section 4.2.1.

4.2.3 SPARE PARTS STORAGE

Spare parts may not arrive at your site with adequate protection for long-term storage unless it was specified in your parts order. It is the customer's responsibility to ensure that all spare parts are prepared and packaged for long term storage. Components such as mechanical seal assemblies and parts should be left in their original sealed containers. The long-term storage of elastomer (rubber) parts must be given consideration since elastomers may have a short shelf live under certain circumstances.

4.3 HANDLING

Use care when moving pumps. Sling pumps so that any protruding components will not be damaged. Do not use choke type sling or chain arrangements for skids or containers.

Make sure that the lifting equipment is rated to safely handle the weight of the pump and auxiliary equipment.

See relevant general arrangement drawings (**Section 8.0**) or bills of materials for weight information.

4.4 MECHANICAL SEAL INSPECTION

The pump was checked during assembly and testing for proper alignment of the pump components. Rough handling during shipment, storage or preparation for installation could cause damage to mechanical seals. **POLARIS PUMPS** are equipped with tandem mechanical seals and should be checked for any oil leakage on the wet end side. This is to ensure that the seal faces did not receive any damage during shipment, storage or preparation for installation.

INSTALLATION, OPERATION AND MAINTENANCE MANUAL			9 of 30
POLARIS - SERIES TBM 200 LH (8") - TYPE PHO / PBO / PVO			
DOCUMENT NBR. : A0455	REVISION: 2	EFFECTIVE DATE:	11-16-2014

4.5 PUMP SET UP / MOUNTING

4.5.1 CABLE AND CHAIN SUSPESION

Pumps of SERIES TBM are fitted with integral lifting lugs sized to accommodate the dead weight of the pump assembly. Verify the weight of your specific pump before making lifting cable or chain selection.

See relevant general arrangement drawings (**Section 8.0**) or bills of materials for weight information.

4.5.2 OPTIONAL LIFTING / SUSPENSION BAIL MOUNTING

Optional lifting bails are available for all pumps of SERIES TBM for applications where a single lifting cable or chain is preferred.

4.5.3 FLOOR MOUNTING

When Pumps are operated resting on the pump stand on the sump floor, they must rest on a horizontal surface that prevents the pump from tipping over and burying itself. A chain or cable with limited slack can be utilized to prevent this.

4.6 PIPING

4.6.1 DISCHARGE HOSE / DISCHARGE PIPING

Flexible, heavy duty, non-collapsible discharge hose is preferred.

All rigid piping must be independently supported. Pump casing should never bear the weight of the piping. Non-collapsible, expansion type joints are recommended on the discharge side of the pump for rigid pipe installations.

INSTALLATION, OPERATION AND MAINTENANCE MANUAL			10 of 30
POLARIS - SERIES TBM 200 LH (8") - TYPE PHO / PBO / PVO			
DOCUMENT NBR. : A0455	REVISION: 2	EFFECTIVE DATE:	11-16-2014

4.6.2 PRIMARY SEAL FLUSH

Polaris pumps equipped with the standard, run dry capable internal slurry seal arrangement do not require an external seal flush or cooling. They are cooled and lubricated by the oil contained in the seal chamber.

The seal flush / cooling water for the available outboard mechanical seal options is automatically supplied if the pump is running. Be aware that if pumps equipped with outboard seals are operated in applications where the sump can be pumped dry, a minimum water level must be present to prevent the mechanical seal from dry running. If the sump level falls below the minimum requirement, the higher than normal seal temperatures could cause the outboard seal faces to crack due to thermal shock once the sump water level rises back and quenches the hot seal faces.

Refer to the general arrangement drawing of your pump (Section 8.0) for the minimum sump level requirement and install suitable level controls.

4.6.3 OPTIONAL WATER JACKET / PIPING

Unless equipped with a continuous dry run rated motor, an optional water jacket **must** be installed if the pump is operated in applications where the sump can be pumped dry below the minimum water level and the **pump remains running under full load for periods exceeding 15 minutes.** This is to prevent overheating and subsequent burnout of the stator windings.

Cooling water should be 5 GPM at 35 P.S.I. maximum pressure at a temperature not exceeding 40°C (104°F).

Water must be **clean** so that no sand, etc., is pumped into the water jacket.

INSTALLATION, OPERATION AND MAINTENANCE MANUAL			11 of 30
POLARIS - SERIES TBM 200 LH (8") - TYPE PHO / PBO / PVO			
DOCUMENT NBR. : A0455	REVISION: 2	EFFECTIVE DATE:	11-16-2014

5.0 ELECTRICAL INSTALLATION

5.1 GENERAL

Power supply and electrical work must be as per local and national codes. All wiring and installation of cables, relays, disconnects, etc., should be performed by qualified personnel. Check that main line voltage and frequency agree with the specifications on the motor data plate. Prior to installation of any wiring, inspect both main power and control cable for possible cuts and tears.

5.2 MOISTURE SENSOR RELAY

Failure to install / operate a suitable Motor Moisture Detection Relay and not connecting the thermal over-load wiring will void your Warranty.

POLARIS PUMPS requires the end user to install a suitable moisture detection relay that must be installed and operational with your pump to validate your warranty.

Suitable Controls are as follows:

WARRICK® TYPE 2810
 AMETEK® 8040
 Pump Saver® Model 460-15-100-SLD

5.3 INSTALLATION

All activities related to the electrical installation, maintenance and operation and service of the motor module must be in accordance with the

**BALDOR® - RELIANCE® ELECTRIC MOTOR
 INSTALLATION & OPERATING MANUAL FOR
 AC SUBMERSIBLE PUMP MOTORS – MN414 (SECTION 8.2)**

See **Section 8.2** of this pump manual.

INSTALLATION, OPERATION AND MAINTENANCE MANUAL			12of 30
POLARIS - SERIES TBM 200 LH (8") - TYPE PHO / PBO / PVO			
DOCUMENT NBR. : A0455	REVISION: 2	EFFECTIVE DATE:	11-16-2014

6.0 OPERATION

6.1 PRE-START UP CHECK

A pre-start up check should always be performed prior to putting your pump into service. The following procedures should be adhered to as a minimum.

- **POWER SUPPLY**

Double-check and confirm that the power supply voltage and frequency match with the pump data plate.

- **WIRING**

Double-check all power and control cable connections. Check and confirm that all ground leads are connected and properly grounded.

- **CONTROL SYSTEM**

Double-check that all control equipment is powered up and operational.

- **CABLES**

Inspect both power and control cables for visual damage such as cuts and tears in the jacket.

- **OIL LEVEL**

Double-check the motor seal oil level (N/A if equipped with Reliance Motor)

- **ROTATION CHECK**

Correct rotation is counter clock wise as viewed from the pump intake side. In case of wrong rotation, switch two of the three main power leads. Do not run the pump in air longer than required to verify proper rotation.

- **COOLING AND FLUSH WATER**

Double-check all connections, hoses and piping and ensure that the water supply is turned on for applications requiring motor cooling. Visually confirm that the cooling water is circulating and exiting through the exhaust opening of the water jacket prior to start up.

INSTALLATION, OPERATION AND MAINTENANCE MANUAL			13 of 30
POLARIS - SERIES TBM 200 LH (8") - TYPE PHO / PBO / PVO			
DOCUMENT NBR. : A0455	REVISION: 2	EFFECTIVE DATE:	11-16-2014

6.2 PUMP START UP

Whenever possible, start the pump in clear liquid to prime discharge piping and/or hoses. If flexible hoses are used, make sure that they are not pinched since the pressure developed by the pump may not be enough to force them open.

Lower the pump slowly into the material to be pumped.

Mixture density can be monitored via a current meter. Higher current draw of the pump will indicate higher density and therefore higher production rate. The mixture density can be controlled by raising or lowering the pump into the material.

Be aware of the mixture characteristics for your specific application. It is important that you maintain a pipeline velocity above the critical settling velocity of the solids mixture being pumped to prevent the solids from settling out and clogging the discharge line.

Never stop the pump while pumping solids through the system. This will plug the piping. Before shut down, raise the pump into clean water and completely flush the discharge line.

During the initial few days of operation while all parts are still new, observe the discharge gauge readings as well as the motor amperage draw. If a flow meter is available, monitor the pump output as well.

These readings should be taken and recorded periodically and will help you to establish an inspection and maintenance schedule. Keeping track of your pumps performance will make it easier to identify problems before they become serious and cause undue damage.

INSTALLATION, OPERATION AND MAINTENANCE MANUAL			14 of 30
POLARIS - SERIES TBM 200 LH (8") - TYPE PHO / PBO / PVO			
DOCUMENT NBR. : A0455	REVISION: 2	EFFECTIVE DATE:	11-16-2014

6.3 PUMP SHUT DOWN

Never stop the pump while pumping solids through the system. This will plug the piping. Lift the pump into clear fluid for as long as it takes to flush the entire system of any slurry.

IMPORTANT

If you operate and store your pump in environments subject to below-freezing temperatures:

1. After the pump has been shut down, completely drain wet end, water jacket and piping. Failure to do so will result in serious damage to your equipment.
2. Be aware that the motor seal oil can thicken during cold storage to the point where it will be too viscous and can not provide adequate lubrication for start-up. Pre-heat the pump as required before start up.
3. Be aware that certain elastomer components (lip seals, o-rings etc.) must not be operated if their temperature is below -4°F (-20°C). Pre-heat the pump as required before start up.

INSTALLATION, OPERATION AND MAINTENANCE MANUAL			15of 30
POLARIS - SERIES TBM 200 LH (8") - TYPE PHO / PBO / PVO			
DOCUMENT NBR. : A0455	REVISION: 2	EFFECTIVE DATE:	11-16-2014

6.4 TROUBLE SHOOTING

6.4.1 FAULT TRACING

To carry out fault tracing on electrical equipment, a multi-meter, test lamp and wiring diagram are required. Fault tracing must be done with the power disconnected unless checks cannot be performed without power to the motor. If a fault is detected, be sure to keep all personnel clear of the pump when the power is turned on. A qualified electrician must perform all electrical work. Obey all local codes and regulations and follow recommended safety procedures.

The following Checklist is designed to aid in identifying possible faults, assuming the pump has been in operation and functioned previously.

All activities related to the electrical installation, maintenance and operation and service of the motor module must be in accordance with the

**BALDOR® - RELIANCE® ELECTRIC MOTOR
 INSTALLATION & OPERATION MANUAL FOR
 SUBMERSIBLE PUMP MOTORS – MN414**

See **Section 8.2** of this pump manual.

- **FAULT SIGNAL AT THE STARTER**

If the stator temperature is too high, check that the pump motor is completely submerged or that the water supply to the water jacket is turned on during operation and that the impeller rotates freely.

In case of a moisture sensor fault, check the condition of the oil and check for water in the motor housing and oil sump. Make sure the overload protection is reset.

INSTALLATION, OPERATION AND MAINTENANCE MANUAL			16 of 30
POLARIS - SERIES TBM 200 LH (8") - TYPE PHO / PBO / PVO			
DOCUMENT NBR. : A0455	REVISION: 2	EFFECTIVE DATE:	11-16-2014

- **FAULT SIGNAL AT THE STARTER, PUMP CAN BE STARTED MANUALLY**

Check for faulty level-control system components (start or high water sensors). Clean or replace as required.

Check for faulty control equipment. Check that all connections are intact. Check relay and actuator windings. Test actuator switch for contact in both manual and automatic mode.

- **PUMP CAN NOT BE STARTED MANUALLY, NO VOLTAGE TO PUMP**

Check that the main power switch is on. Check for control voltage to the starter equipment and that all fuses are intact.

Check that all supply line phases are live and that all fuses are intact and properly fitted. Check that the overload protection relay is reset. Check for breaks in the motor cable.

- **PUMP CAN NOT BE STARTED MANUALLY, VOLTAGE IS GOING TO PUMP**

If this is the case, some oversized material or other debris may have jammed the impeller, solids mixer or shredder.

CAUTION: Disconnect and lock out the main power supply before working in the intake area of the pump. Failure to do so can result in serious injury.

Clean out and remove any objects that may have jammed the impeller and inspect the pump components for any visual damage. Inspect the sump area and remove any oversized material and debris. Inspect pump strainer for excessive wear and replace if required.

- **PUMP CAN BE STARTED, MOTOR PROTECTION TRIPS**

Check that the overload protection is not set too low or is defective. Check the breaker set point vs. the amperage on the motor data plate and adjust or replace overload protection relay as required.

Check for free rotation of the impeller. If it is not easily rotated, or feels tight, check for tramp material within the pump. Using an Amp-meter, check the current on all three phases. Using a Meg-ohm meter, check the insulation between the phases and ground. If the phase amp readings are too high or uneven, or a ground fault is detected, contact **POLARIS PUMPS**.

INSTALLATION, OPERATION AND MAINTENANCE MANUAL			17 of 30
POLARIS - SERIES TBM 200 LH (8") - TYPE PHO / PBO / PVO			
DOCUMENT NBR. :	A0455	REVISION:	2
		EFFECTIVE DATE:	11-16-2014

- **PUMP IS EXPECTED TO STOP BUT KEEPS RUNNING**

If the pump has been running satisfactory and is capable of emptying the sump to the control stop level, check for leakage in discharge piping and connections. Leakage water may be re-circulated back into the sump. Check that the impeller or suction is not clogged.

CAUTION: Disconnect and lock out the main power supply before working in the intake area of the pump. Failure to do so can result in serious injury. Clean out and remove any objects that may have clogged the impeller and inspect the pump components for any visual damage. Inspect the sump area and remove any oversized material and debris. Inspect pump strainer for excessive wear and replace if required. Check that the impeller and casing are not worn and need to be replaced. Check the impeller running clearance and adjust as required.

Check for faults in the level control equipment. Clean and inspect the level sensor probes and perform a function test. Check the level control relay contactor and holding circuit. Replace any faulty components. Check the location of the stop level probe to ensure it is not set too low.

- **PUMP STARTS AND STOPS REPEATEDLY**

Check if the back flow from the discharge pipe is enough to raise the sump level to the level-controller starting probe. If so, positioning a rubber flap valve in the discharge pipe close enough to the pump will minimize back-flow. Check that the distance between start and stop level probes is not too short. Check that the contactor does not break its self-holding function. Check the voltage in the control circuit in relation to the rated voltage on the coil. Check the functioning of the stop sensor probe. The voltage drop in the line during the start-up surge can cause the contactor self-holding function to break.

INSTALLATION, OPERATION AND MAINTENANCE MANUAL			18 of 30
POLARIS - SERIES TBM 200 LH (8") - TYPE PHO / PBO / PVO			
DOCUMENT NBR. : A0455	REVISION: 2	EFFECTIVE DATE:	11-16-2014

- **PUMP IS RUNNING WITH REDUCED FLOW**

This can be caused by either pump and / or system related problems.

Check your system set-up:

Verify that all piping connections are tight and that there are no leaks in the discharge line.

Check that any valves are fully open and operable and the discharge line and valves are not clogged.

Check your system-head requirement. The pump flow will reduce if the point of discharge has been raised or additional piping has been added.

Check your pump:

Verify proper direction of rotation.

Check the pump intake area to ensure that the impeller, strainer and mixer or shredder is not clogged.

Visually inspect the wet-end components for wear. The performance of the pump can be significantly reduced if casing and impeller have experienced excessive wear. Check the impeller running clearance and adjust if required. Replace parts as required.

Copyright Polaris Pumps LLC

INSTALLATION, OPERATION AND MAINTENANCE MANUAL			19 of 30
POLARIS - SERIES TBM 200 LH (8") - TYPE PHO / PBO / PVO			
DOCUMENT NBR. : A0455	REVISION: 2	EFFECTIVE DATE:	11-16-2014

7.0 WET END INSTALLATION

Inspect and inventory all parts before you begin assembly. Clean all parts and remove protective coatings as required. Inspect the motor module for any visual damage paying particular attention to the shaft end and mechanical seal. Remove any protective coatings from the shaft end and check to make sure that the tapped hole in the end of the shaft and the key seat are free of any shavings and dirt. Prior to the physical assembly of the wet end, familiarize yourself with all of the components and the assembly sequence by reading the assembly instructions and the enclosed explosion drawings. Based on your particular pump model and size gather the necessary tools as per the following tool list.

TOOL REQUIREMENTS

Series TBM - 200 LH - Type "PHO"

- Allen wrenches 5/8" - 14 mm - 6 mm, Torque Wrench
- Plastic or Rubber Hammer
- Nickel Based "Never-Seize" or "Molykote®"
- Loctite® 262 High Strength or Devcon® Super Lock 2271
- Loctite® 242 Medium Strength

Series TBM - 200 LH - Types "PBO" and "PVO"

- Allen wrenches 5/8" - 14 mm - 8 mm - 5 mm, Torque Wrench
- Open ended wrench 2" or 51 mm
- Plastic or Rubber Hammer
- Nickel Based "Never-Seize" or "Molykote®"
- Loctite® 262 High Strength or Devcon® Super Lock 2271
- Loctite® 242 Medium Strength

INSTALLATION, OPERATION AND MAINTENANCE MANUAL			20 of 30
POLARIS - SERIES TBM 200 LH (8") - TYPE PHO / PBO / PVO			
DOCUMENT NBR. : A0455	REVISION: 2	EFFECTIVE DATE:	11-16-2014

7.1 TBM 200 LH - TYPE PHO Drawing A0207 and A0210

Refer to Appendix 8.4 (A0432) for Fastener Torque requirements

Apply "Never-Seize" to the motor shaft end. Position Flinger Gasket (Item 060.2) onto shaft. Insert Drive Key (Item 113) into the key seat. Slide Flinger (Item 110) onto the shaft. Position Impeller Gasket (Item 060.1) against the Impeller flinger.

Hoist the Volute Casing (Item 102) into position and insert into the motor flange spigot. Apply Loctite® 242 to the Socket Head Cap Screws and insert with Lock Washers (Items 040.1, 040.4) through the motor flange into the Casing and tighten.

Slide the Impeller (Item 101) onto the shaft. Position the O-ring (Item 062.2) onto the Impeller Cap (Item 107) and the same into the impeller bore, lining up the groove in the cap face with the key. Position O-Ring (Item 062.1) onto the Impeller Lock Screw (Item 040.3), apply Loctite® 262 and insert into the shaft end and tighten.

Refer to Appendix 8.4 (A0431) for Impeller Installation and Lock Screw Torque

Position Casing Gaskets (Item 060.3) onto Strainer (Item 103), aligning the holes. To verify the impeller running clearance, compare the depth from the top of the strainer to the gaskets with the depth from the casing face to the impeller vanes. The total difference should be 1/32" – 1/16". Adjust as necessary by adding or subtracting casing gaskets.

Slide strainer and gaskets into the casing bore. Position the Pump Stand (Item 112) over the strainer, insert Loctite® 242 coated Socket Head Cap Screws and Lock Washers (Items 040.2, 040.4) and tighten.

Apply Loctite® 242 to the Countersunk Head Cap Screws (Item 040.5), insert the Intake Screen (Item 111) and screws into the strainer and tighten.

POLARIS

PUMPS

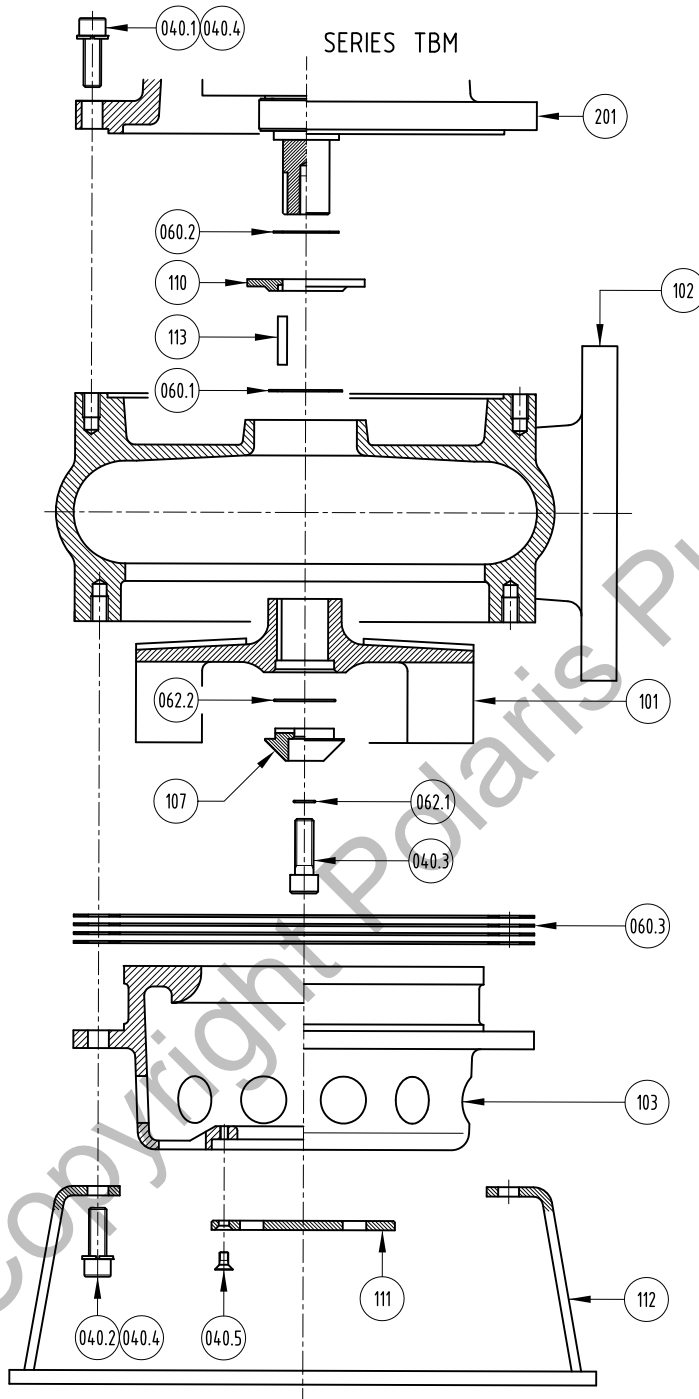

WET END ASSEMBLY - EXPLOSION		FOR BILL OF MATERIALS / PARTS LIST SEE: A0210
TBM 200 LH-PHO		
DRAWING NBR.: A0207	REV.: 2	
EFFECTIVE DATE : 11-16-2014		



POLARIS PUMPS - SERIES TBM - 200 LH TYPE PHO											A0210 (Rev.1)	
ITEM	ITEM	ITEM	PART NUMBER	QTY.	DESCRIPTION	EXT. DESC.1	MODEL1	MODEL 2	WT.(KG)	WT.(lbs)	MTL.	DWG. #
151			151.200.05.00240	1	KIT, WET END - BASIC		TBM 200LH		375.57	826.37		
	101		101.012.05.00213	1	IMPELLER	RH, 5V	TBM 200LH	PHO, PBO, PVO			A532 CL III TP. A	C0182
	102		102.012.05.00215	1	CASING	VOLUTE	TBM 200LH	PHO, PBO, PVO			A532 CL III TP. A	D0184
	103		103.012.05.00217	1	LINER	SUCTION	TBM 200LH	PHO, PBO, PVO			A532 CL III TP. A	D0186
	110		110.082.05.00228	1	FLINGER		TBM 200LH	FRAME 320TY/360TYS			ASTM A564 Gr.630 (17-4 PH)	B0193
	112		112.056.05.00231	1	STAND	PUMP	TBM 200LH	PHO, PBO, PVO			ASTM A36	C0197
	113		113.085.05.01490	1	KEY	DRIVE	FRAME 320TY/360TYS	PHO, PBO, PVO			304SS	B0111
	041.1		041.200.05.00260	1	KIT, FASTENER						A4/70	
		040.1	040.084.00.00254	8	FASTENER	SCREW	HEX SOCKT.HD.CAP	DIN 912 / M16 X 55			A4/70	
		040.2	040.084.00.00255	8	FASTENER	SCREW	HEX SOCKT.HD.CAP	DIN 912 / M16 X 70			A4/70	
		040.3	040.084.00.00257	1	FASTENER	SCREW	HEX SOCKT.HD.CAP	ANSI B18.3 / 3/4"UNC X 2.50"			A4/70	
		040.4	040.084.00.00070	16	FASTENER	WASHER	LOCK	DIN 127B / M16				
	061.1		061.200.05.00252	1	KIT, GASKET						GYLON-3500	
		060.1	060.101.05.00232	1	GASKET	IMPELLER	FRAME 320 TY / 360 TYS	PHO, PBO, PVO			GYLON-3500, .031"	B0044
		060.2	060.101.05.00233	1	GASKET	FLINGER	FRAME 320 TY / 360 TYS	PHO, PBO, PVO			GYLON-3500, .031"	B0044
	061.2		061.200.05.00253	1	KIT, GASKET						BLUE-GARD	
		060.3	060.102.05.00234	4	GASKET	CASING	TBM200LH	PHO, PBO, PVO			"BLUE GARD", .125"	B0045
152			152.200.05.00241	1	KIT, INTAKE SCREEN		TBM 200LH-200MH	PHO	3.57	7.85		
	111		111.053.05.00229	1	SCREEN	INTAKE	TBM 200LH-200MH	PHO			QT400	B0195
	041.2		041.200.05.00261	1	KIT, FASTENER						A4/70	
		040.5	040.084.00.00258	3	FASTENER	SCREW	HEX SOCKT, CSK.HD.FLAT	DIN 7991 / M12 X 30			A4/70	
153			153.200.05.00242	1	KIT, IMPELLER CAP		TBM 200LH-200MH	PHO	1.75	3.85		
	107		107.082.05.00225	1	CAP	IMPELLER	TBM 200LH-200MH	PHO			ASTM A564 Gr.630 (17-4 PH)	B0191
	063.1		063.200.05.00246	1	KIT, O-RING						72 NBR	
		062.1	062.131.00.00249	1	O-RING	18 x 2					72 NBR	
		062.2	062.131.00.00248	1	O-RING	80 x 3					72 NBR	

INSTALLATION, OPERATION AND MAINTENANCE MANUAL			23of 30
POLARIS - SERIES TBM 200 LH (8") - TYPE PHO / PBO / PVO			
DOCUMENT NBR. :	A0455	REVISION:	2
		EFFECTIVE DATE:	11-16-2014

7.2 TBM 200 LH - TYPE PBO

Drawing **A0208** and **A0211**

Refer to Appendix 8.4 (A0432) for Fastener Torque requirements

Apply "Never-Seize" to the motor shaft end. Position Flinger Gasket (Item 060.2) onto shaft. Insert Drive Key (Item 113) into the key seat. Slide Flinger (Item 110) onto the shaft. Position Impeller Gasket (Item 060.1) against the Impeller flinger.

Hoist the Volute Casing (Item 102) into position and insert into the motor flange spigot. Apply Loctite® 242 to the Socket Head Cap Screws and insert with Lock Washers (Items 040.1, 040.4) through the motor flange into the Casing and tighten.

Slide the Impeller (Item 101) onto the shaft. Position the O-rings (Item 062.2, 062.3) onto the Shaft Adapter (Item 108) and the same into the impeller bore, lining up the groove in the cap face with the key. Position O-Ring (Item 062.1) onto the Impeller Lock Screw (Item 040.3), apply Loctite® 262 and insert into the shaft end and tighten.

Refer to Appendix 8.4 (A0431) for Impeller Installation and Lock Screw Torque

Apply "Never-Seize" to the adapter thread and screw on the Shaft Extension (Item 109). Tighten the shaft extension via the wrench flats on the outboard end. Position the O-ring (Item 062.4) into the shaft extension thread relief.

Position Casing Gaskets (Item 060.3) onto Strainer (Item 103), aligning the holes. To verify the impeller running clearance, compare the depth from the top of the strainer to the gaskets with the depth from the casing face to the impeller vanes. The total difference should be 1/32" – 1/16". Adjust as necessary by adding or subtracting casing gaskets.

Slide strainer and gaskets into the casing bore. Position the Pump Stand (Item 112) over the strainer, insert Loctite® 242 coated Socket Head Cap Screws and Lock Washers (Items 040.2, 040.4) and tighten.

Apply Loctite® 242 to the Countersunk Head Cap Screws (Item 040.5), insert the Intake Screen (Item 111) and screws into the strainer and tighten.

Apply "Never-Seize" to the shaft extension thread and screw on the Solids Mixer (Item 106). Tighten using a plastic or rubber hammer.

POLARIS

PUMPS

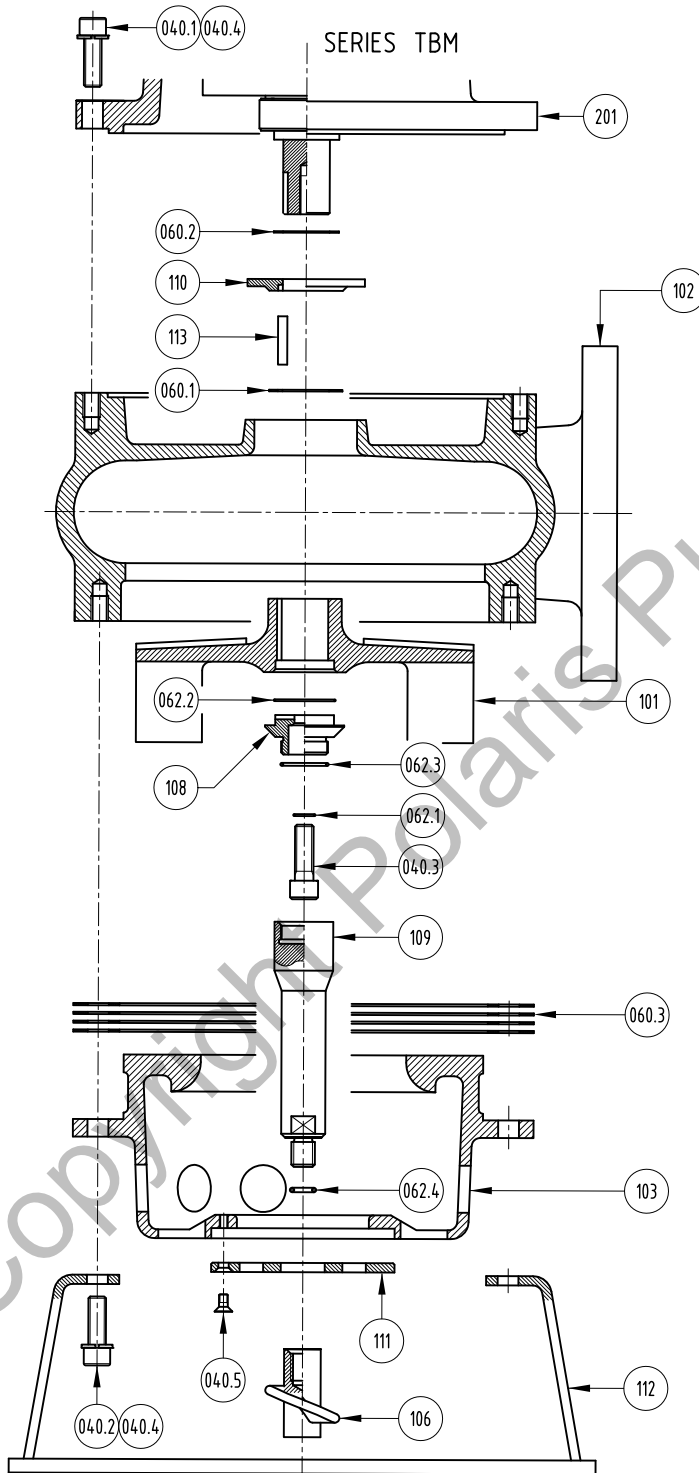

WET END ASSEMBLY - EXPLOSION		FOR BILL OF MATERIALS / PARTS LIST SEE: A0211
TBM 200 LH-PBO		
DRAWING NBR.: A0208	REV.: 2	
EFFECTIVE DATE : 11-16-2014		



P U M P S

ORIGINAL SOLUTIONS. NO COMPROMISES.

POLARIS PUMPS - SERIES TBM - 200 LH TYPE PBO											A0211 (Rev.1)	
ITEM	ITEM	ITEM	PART NUMBER	QTY.	DESCRIPTION	EXT. DESC.1	MODEL1	MODEL 2	WT.(KG)	WT.(lbs)	MTL.	DWG. #
151			151.200.05.00240	1	KIT, WET END - BASIC		TBM 200LH		375.57	826.37		
	101		101.012.05.00213	1	IMPELLER	RH, 5V	TBM 200LH	PHO, PBO, PVO			A532 CL III TP. A	C0182
	102		102.012.05.00215	1	CASING	VOLUTE	TBM 200LH	PHO, PBO, PVO			A532 CL III TP. A	D0184
	103		103.012.05.00217	1	LINER	SUCTION	TBM 200LH	PHO, PBO, PVO			A532 CL III TP. A	D0186
	110		110.082.05.00228	1	FLINGER		TBM 200LH	FRAME 320TY/360TYS			ASTM A564 Gr.630 (17-4 PH)	B0193
	112		112.056.05.00231	1	STAND	PUMP	TBM 200LH	PHO, PBO, PVO			ASTM A36	C0197
	113		113.085.05.01490	1	KEY	DRIVE	FRAME 320TY/360TYS	PHO, PBO, PVO			304SS	B0111
	041.1		041.200.05.00260	1	KIT, FASTENER						A4/70	
		040.1	040.084.00.00254	8	FASTENER	SCREW	HEX SOCKT.HD.CAP	DIN 912 / M16 X 55			A4/70	
		040.2	040.084.00.00255	8	FASTENER	SCREW	HEX SOCKT.HD.CAP	DIN 912 / M16 X 70			A4/70	
		040.3	040.084.00.00257	1	FASTENER	SCREW	HEX SOCKT.HD.CAP	ANSI B18.3 / 3/4"UNC X 2.50"			A4/70	
		040.4	040.084.00.00070	16	FASTENER	WASHER	LOCK	DIN 127B / M16				
	061.1		061.200.05.00252	1	KIT, GASKET						GYLON-3500	
		060.1	060.101.05.00232	1	GASKET	IMPELLER	FRAME 320 TY / 360 TYS	PHO, PBO, PVO			GYLON-3500, .031"	B0044
		060.2	060.101.05.00233	1	GASKET	FLINGER	FRAME 320 TY / 360 TYS	PHO, PBO, PVO			GYLON-3500, .031"	B0044
	061.2		061.200.05.00253	1	KIT, GASKET						BLUE-GARD	
		060.3	060.102.05.00234	4	GASKET	CASING	TBM200LH	PHO, PBO, PVO			"BLUE GARD", .125"	B0045
154			154.200.05.00243	1	KIT, MIXER		TBM 200LH-200MH	PBO	6.37	14.05		
	106		106.012.05.00223	1	MIXER	ROTATING	TBM 200LH-200MH	PBO			A532 CL III TP. A	C0188
	111		111.053.05.00230	1	SCREEN	INTAKE	TBM 200LH-200MH	PBO			QT400	B0196
	041.2		041.200.05.00261	1	KIT, FASTENER						A4/70	
		040.5	040.084.00.00258	3	FASTENER	SCREW	HEX SOCKT, CSK.HD.FLAT	DIN 7991 / M12 X 30			A4/70	
156			156.200.05.00245	1	KIT, SHAFT EXTENSION		TBM 200LH-200MH	PBO, PVO	1.75	3.85		
	108		108.082.05.00226	1	ADAPTER	SHAFT	TBM 200LH-200MH	PBO, PVO			ASTM A564 Gr.630 (17-4 PH)	B0192
	109		109.082.05.00227	1	EXTENSION	SHAFT	TBM 200LH-200MH	PBO, PVO			ASTM A564 Gr.630 (17-4 PH)	B0190
	063.1		063.200.05.00246	1	KIT, O-RING						72 NBR	
		062.1	062.131.00.00249	1	O-RING	18 x 2					72 NBR	
		062.2	062.131.00.00248	1	O-RING	80 x 3					72 NBR	
	063.2		063.200.05.00247	1	KIT, O-RING						72 NBR	
		062.3	062.131.00.00250	1	O-RING	50 x 3					72 NBR	
		062.4	062.131.00.00251	1	O-RING	20 x 6					72 NBR	

INSTALLATION, OPERATION AND MAINTENANCE MANUAL			26 of 30
POLARIS - SERIES TBM 200 LH (8") - TYPE PHO / PBO / PVO			
DOCUMENT NBR. :	A0455	REVISION:	2
		EFFECTIVE DATE:	11-16-2014

7.3 TBM 200 LH - TYPE PVO Drawing **A0209** and **A0212**

Refer to Appendix 8.4 (A0432) for Fastener Torque requirements

Apply "Never-Seize" to the motor shaft end. Position Flinger Gasket (Item 060.2) onto shaft. Insert Drive Key (Item 113) into the key seat. Slide Flinger (Item 110) onto the shaft. Position Impeller Gasket (Item 060.1) against the Impeller flinger.

Hoist the Volute Casing (Item 102) into position and insert into the motor flange spigot. Apply Loctite® 242 to the Socket Head Cap Screws and insert with Lock Washers (Items 040.1, 040.4) through the motor flange into the Casing and tighten.

Slide the Impeller (Item 101) onto the shaft. Position the O-rings (Item 062.2, 062.3) onto the Shaft Adapter (Item 108) and the same into the impeller bore, lining up the groove in the cap face with the key. Position O-Ring (Item 062.1) onto the Impeller Lock Screw (Item 040.3), apply Loctite® 242 and insert into the shaft end and tighten.

Refer to Appendix 8.4 (A0431) for Impeller Installation and Lock Screw Torque

Apply "Never-Seize" to the adapter thread and screw on the Shaft Extension (Item 109). Tighten the shaft extension via the wrench flats on the outboard end. Position the O-ring (Item 062.4) into the shaft extension thread relief.

Position Casing Gaskets (Item 060.3) onto Strainer (Item 103), aligning the holes. To verify the impeller running clearance, compare the depth from the top of the strainer to the gaskets with the depth from the casing face to the impeller vanes. The total difference should be 1/32" – 1/16". Adjust as necessary by adding or subtracting casing gaskets.

Slide strainer and gaskets into the casing bore. Position the Pump Stand (Item 112) over the strainer, insert Loctite® 242 coated Socket Head Cap Screws and Lock Washers (Items 040.2, 040.4) and tighten.

Apply Loctite® 242 to the Socket Head Cap Screws (Item 040.6) and insert the Stationary Shredder (Item 105) and screws into the strainer. Apply Loctite® 242 to the Set- Screws (Item 040.7) and insert into stationary shredder. Apply "Never-Seize" to the shaft extension thread and screw on the Rotating Shredder (Item 104). Tighten using a plastic or rubber hammer. Adjust shredder clearance to 0.5 mm (0.020") using the set-screws and tighten the socket head cap screws.

POLARIS

PUMPS

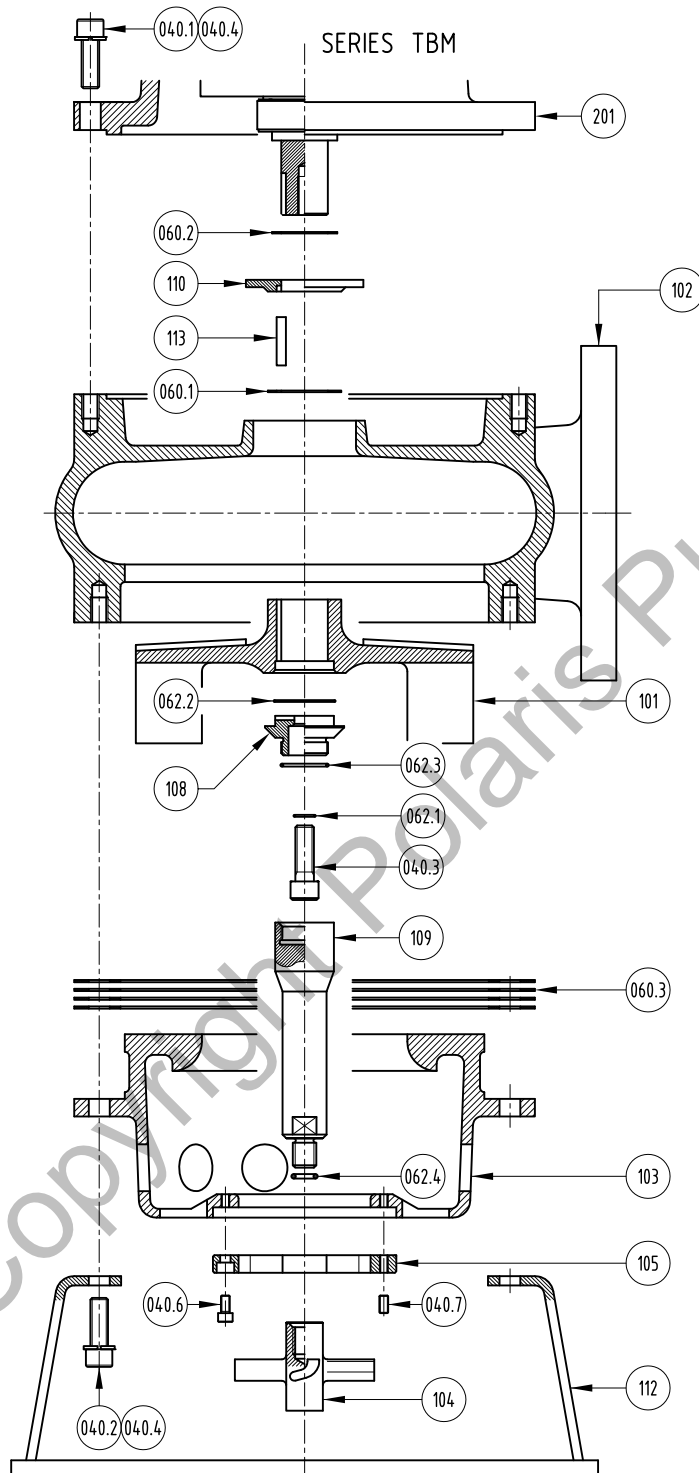

WET END ASSEMBLY - EXPLOSION		FOR BILL OF MATERIALS / PARTS LIST SEE: A0212
TBM 200 LH-PVO		
DRAWING NBR.: A0209	REV.: 2	
EFFECTIVE DATE : 11-16-14		



P U M P S

ORIGINAL SOLUTIONS. NO COMPROMISES.

POLARIS PUMPS - SERIES TBM - 200 LH TYPE PVO											A0212 (Rev.1)	
ITEM	ITEM	ITEM	PART NUMBER	QTY.	DESCRIPTION	EXT. DESC.1	MODEL1	MODEL 2	WT.(KG)	WT.(lbs)	MTL.	DWG. #
151			151.200.05.00240	1	KIT, WET END - BASIC		TBM 200LH		375.57	826.37		
	101		101.012.05.00213	1	IMPELLER	RH, 5V	TBM 200LH	PHO, PBO, PVO			A532 CL III TP. A	C0182
	102		102.012.05.00215	1	CASING	VOLUTE	TBM 200LH	PHO, PBO, PVO			A532 CL III TP. A	D0184
	103		103.012.05.00217	1	LINER	SUCTION	TBM 200LH	PHO, PBO, PVO			A532 CL III TP. A	D0186
	110		110.082.05.00228	1	FLINGER		TBM 200LH	FRAME 320TY/360TYS			ASTM A564 Gr.630 (17-4 PH)	B0193
	112		112.056.05.00231	1	STAND	PUMP	TBM 200LH	PHO, PBO, PVO			ASTM A36	C0197
	113		113.085.05.01490	1	KEY	DRIVE	FRAME 320TY/360TYS	PHO, PBO, PVO			304SS	B0111
041.1			041.200.05.00260	1	KIT, FASTENER						A4/70	
	040.1		040.084.00.00254	8	FASTENER	SCREW	HEX SOCKT.HD.CAP	DIN 912 / M16 X 55			A4/70	
	040.2		040.084.00.00255	8	FASTENER	SCREW	HEX SOCKT.HD.CAP	DIN 912 / M16 X 70			A4/70	
	040.3		040.084.00.00257	1	FASTENER	SCREW	HEX SOCKT.HD.CAP	ANSI B18.3 / 3/4"UNC X 2.50"			A4/70	
	040.4		040.084.00.00070	16	FASTENER	WASHER	LOCK	DIN 127B / M16				
061.1			061.200.05.00252	1	KIT, GASKET						GYLON-3500	
	060.1		060.101.05.00232	1	GASKET	IMPELLER	FRAME 320 TY / 360 TYS	PHO, PBO, PVO			GYLON-3500, .031"	B0044
	060.2		060.101.05.00233	1	GASKET	FLINGER	FRAME 320 TY / 360 TYS	PHO, PBO, PVO			GYLON-3500, .031"	B0044
061.2			061.200.05.00253	1	KIT, GASKET						BLUE-GARD	
	060.3		060.102.05.00234	4	GASKET	CASING	TBM200LH	PHO, PBO, PVO			"BLUE GARD", .125"	B0045
155			155.200.05.00244	1	KIT, SHREDDER		TBM 200LH-200MH	PVO	7.50	16.50		
	104		104.012.05.00219	1	SHREDDER	ROTATING	TBM 200LH-200MH	PVO			A532 CL III TP. A	C0200
	105		105.012.05.00221	1	SHREDDER	STATIONARY	TBM 200LH-200MH	PVO			A532 CL III TP. A	C0202
041.2			041.200.05.00262	1	KIT, FASTENER						A4/70	
	040.6		040.084.00.00256	3	FASTENER	SCREW	HEX SOCKT.HD.CAP	DIN 912 / M12 X 35			A4/70	
	040.7		040.084.00.00259	3	FASTENER	SCREW	HEX SOCKT.SET	DIN 913 / M12 X 20			A4/70	
156			156.200.05.00245	1	KIT, SHAFT EXTENSION		TBM 200LH-200MH	PBO, PVO	7.80	17.16		
	108		108.082.05.00226	1	ADAPTER	SHAFT	TBM 200LH-200MH	PBO, PVO			ASTM A564 Gr.630 (17-4 PH)	B0192
	109		109.082.05.00227	1	EXTENSION	SHAFT	TBM 200LH-200MH	PBO, PVO			ASTM A564 Gr.630 (17-4 PH)	B0190
063.1			063.200.05.00246	1	KIT, O-RING						72 NBR	
	062.1		062.131.00.00249	1	O-RING	18 x 2					72 NBR	
	062.2		062.131.00.00248	1	O-RING	80 x 3					72 NBR	
063.2			063.200.05.00247	1	KIT, O-RING						72 NBR	
	062.3		062.131.00.00250	1	O-RING	50 x 3					72 NBR	
	062.4		062.131.00.00251	1	O-RING	20 x 6					72 NBR	

INSTALLATION, OPERATION AND MAINTENANCE MANUAL			29 of 30
POLARIS - SERIES TBM 200 LH (8") - TYPE PHO / PBO / PVO			
DOCUMENT NBR. :	A0455	REVISION:	2
		EFFECTIVE DATE:	11-16-2014

8.0 APPENDIX

- 8.1 PUMP GENERAL ARRANGEMENT DRAWING, TBM 200 LH – PHO, PBO, PVO
 - TBM 200 LH – 40 / 50 / 60 HP MOTOR
 - TBM 200 LH – 75 / 100 / 125 HP MOTOR
 - 8.1.1 PUMP PERFORMANCE CURVE - TYPE PHO
 - 8.1.2 PUMP PERFORMANCE CURVE - TYPE PBO
 - 8.1.3 PUMP PERFORMANCE CURVE - TYPE PVO
- 8.2 BALDOR® - RELIANCE® ELECTRIC MOTOR
 INSTALLATION & OPERATION MANUAL FOR
 SUBMERSIBLE PUMP MOTORS – MN414
- 8.3 -
- 8.4 IMPELLER INSTALLATION / BOLT TORQUE SPECIFICATIONS

Copyright Polaris Pumps LLC

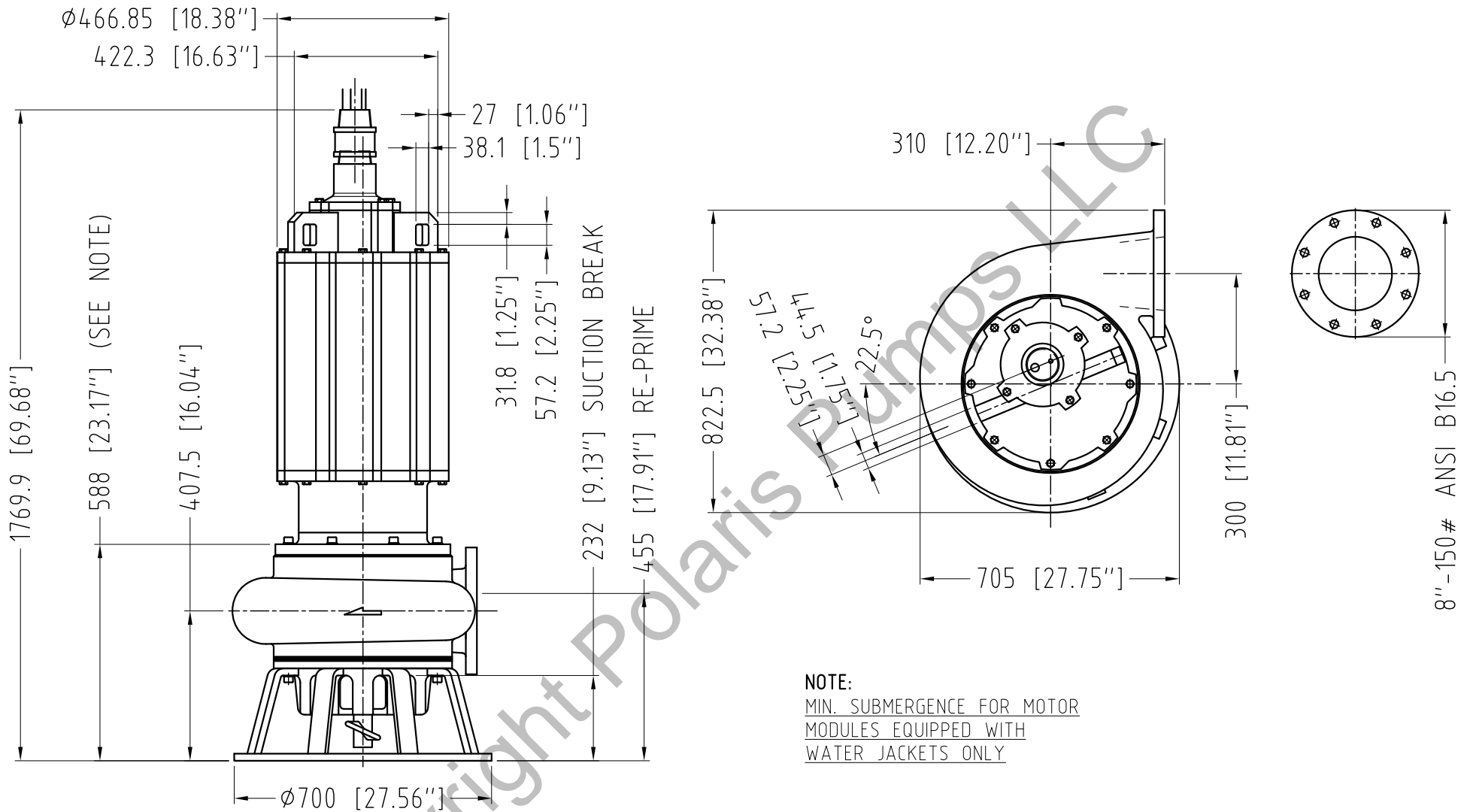

GENERAL ARRANGEMENT, WEIGHTS	
TBM 200 LH-PHO, PBO, PVO (75 - 125 HP 6P Motors) (60 - 150 HP 8P Motors)	
DRAWING NBR.: A0198	REV.: 2
EFFECTIVE DATE : 08/12/2012	

POLARIS
PUMPS

PUMP MODEL	WEIGHT (lbs.)	WEIGHT (kg)
TBM 200 LH - PHO	2354	1070
TBM 200 LH - PBO	2365	1075
TBM 200 LH - PVO	2369.4	1077

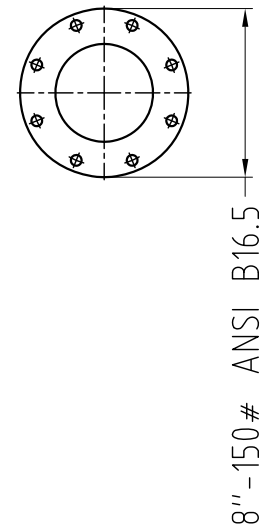
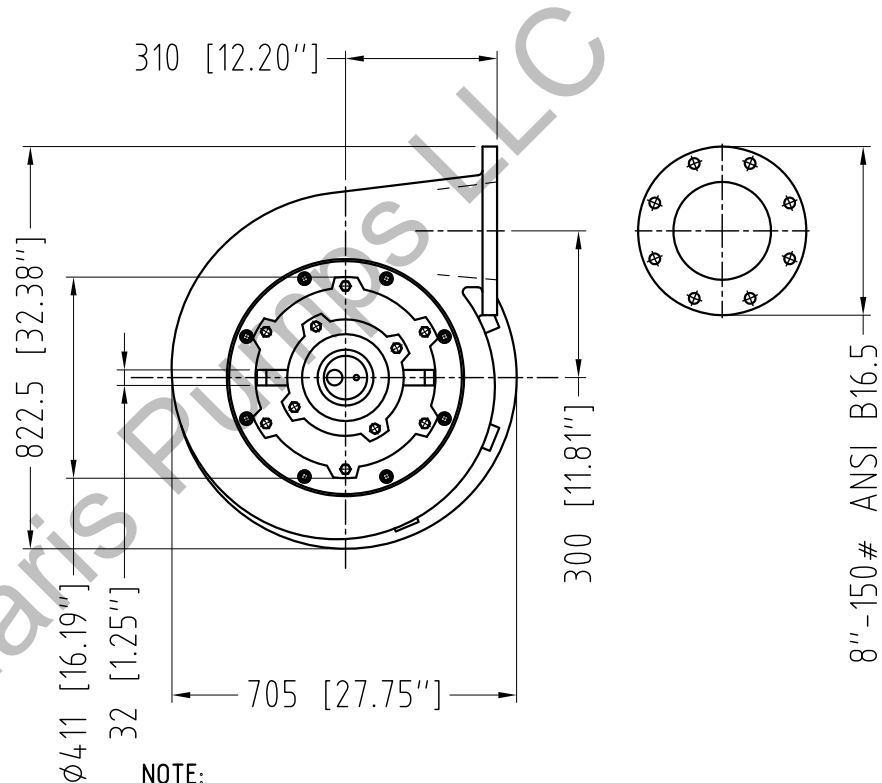
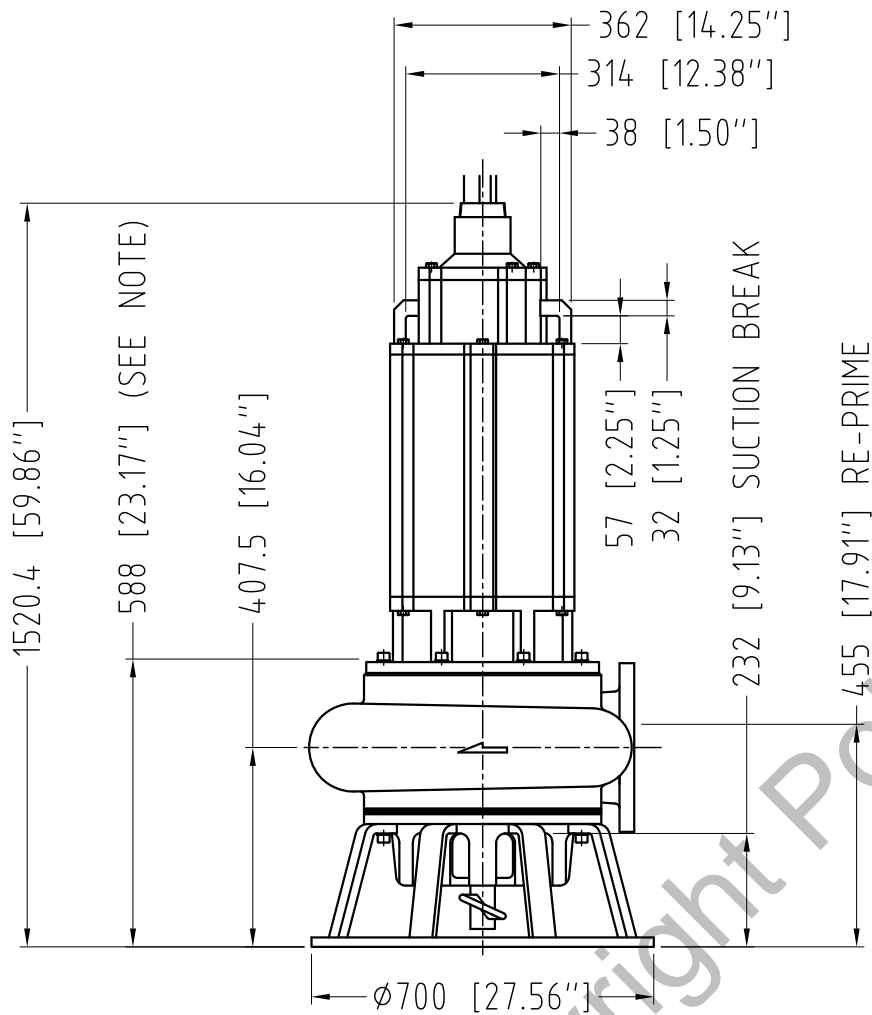

NOTE:
 MIN. SUBMERGENCE FOR MOTOR
 MODULES EQUIPPED WITH
 WATER JACKETS ONLY

GENERAL ARRANGEMENT, WEIGHTS TBM 200 LH-PHO, PBO, PVO (40 - 60 HP 6P Motors) (30 - 40 HP 8P Motors)	
DRAWING NBR.: A0199	REV.: 2
EFFECTIVE DATE : 08/05/2012	

POLARIS
 P U M P S

PUMP MODEL	WEIGHT (lbs.)	WEIGHT (kg)
TBM 200 LH - PHO	2004	911
TBM 200 LH - PBO	2015	916
TBM 200 LH - PVO	2019.4	918

POLARIS

PUMPS

PUMP MODEL TBM 200 LH-PHO	CURVE NBR.: A0213	DISCHARGE ϕ (In) : 8	NUMBER OF VANES : 5
	REVISION : 2	IMPELLER ϕ (In) : 14.76	FRAME REF. : 320TY-360TYS
	TEST NBR.: TBM200LH-PBO-001	MAX. SOLIDS ϕ (In) : 1.58	FREQUENCY : 60 Hz
	EFFECTIVE DATE : 04-04-02	PERFORMANCE FOR <u>CLEAR WATER</u> @ 68°F/20°C AND 1.0 S.G. CORRECT FOR OTHER CONDITIONS AND/OR SOLIDS EFFECT	
	APPROVED BY : UJB		

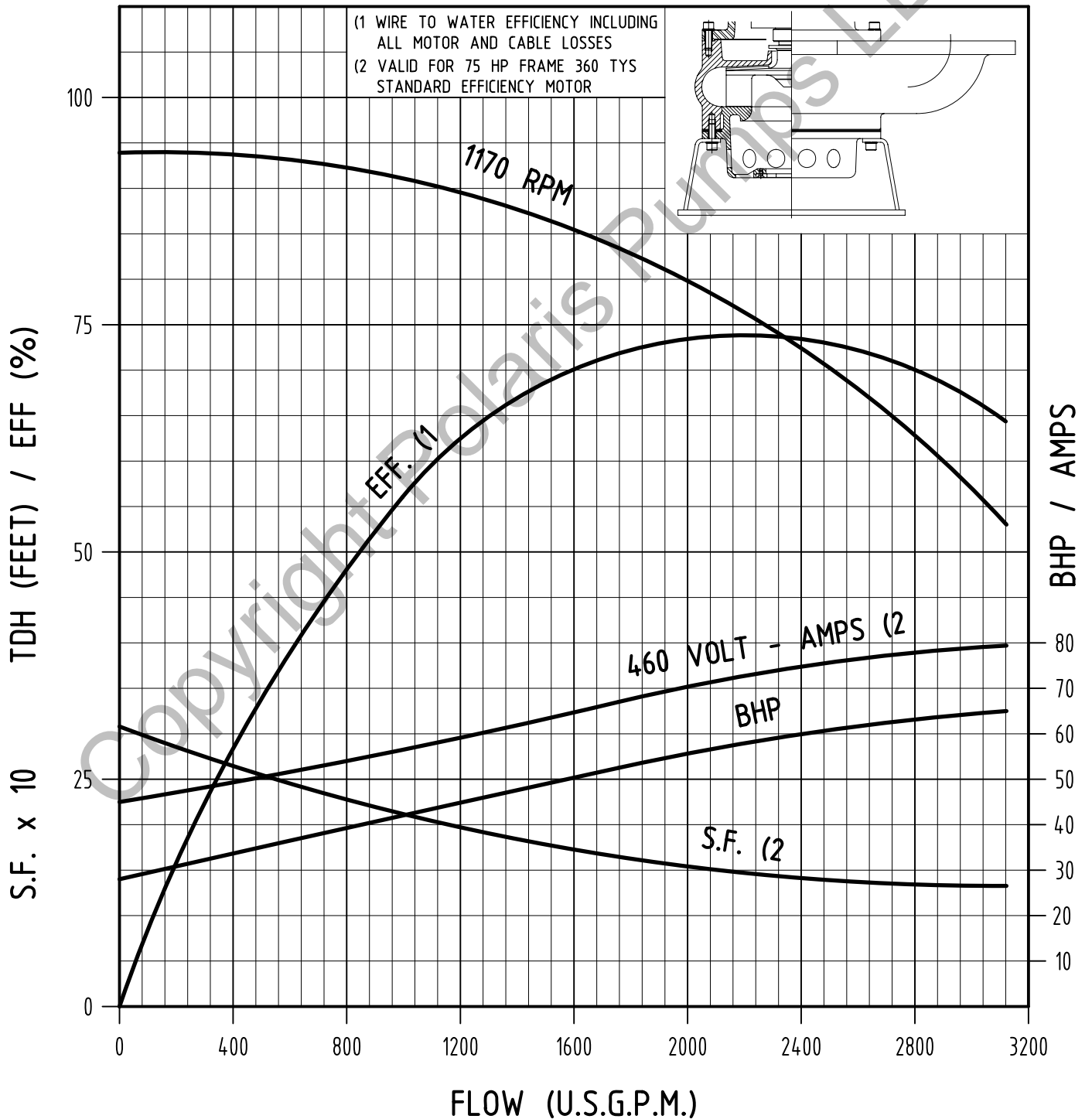

POLARIS

PUMPS

PUMP MODEL TBM 200 LH-PBO	CURVE NBR.: A0214	DISCHARGE ϕ (In) : 8	NUMBER OF VANES : 5
	REVISION : 2	IMPELLER ϕ (In) : 14.76	FRAME REF. : 320TY-360TYS
	TEST NBR.: TBM200LH-PBO-001	MAX. SOLIDS ϕ (In) : 1.58	FREQUENCY : 60 Hz
	EFFECTIVE DATE : 04-04-02	PERFORMANCE FOR <u>CLEAR WATER</u> @ 68°F/20°C AND 1.0 S.G. CORRECT FOR OTHER CONDITIONS AND/OR SOLIDS EFFECT	
	APPROVED BY : UJB		

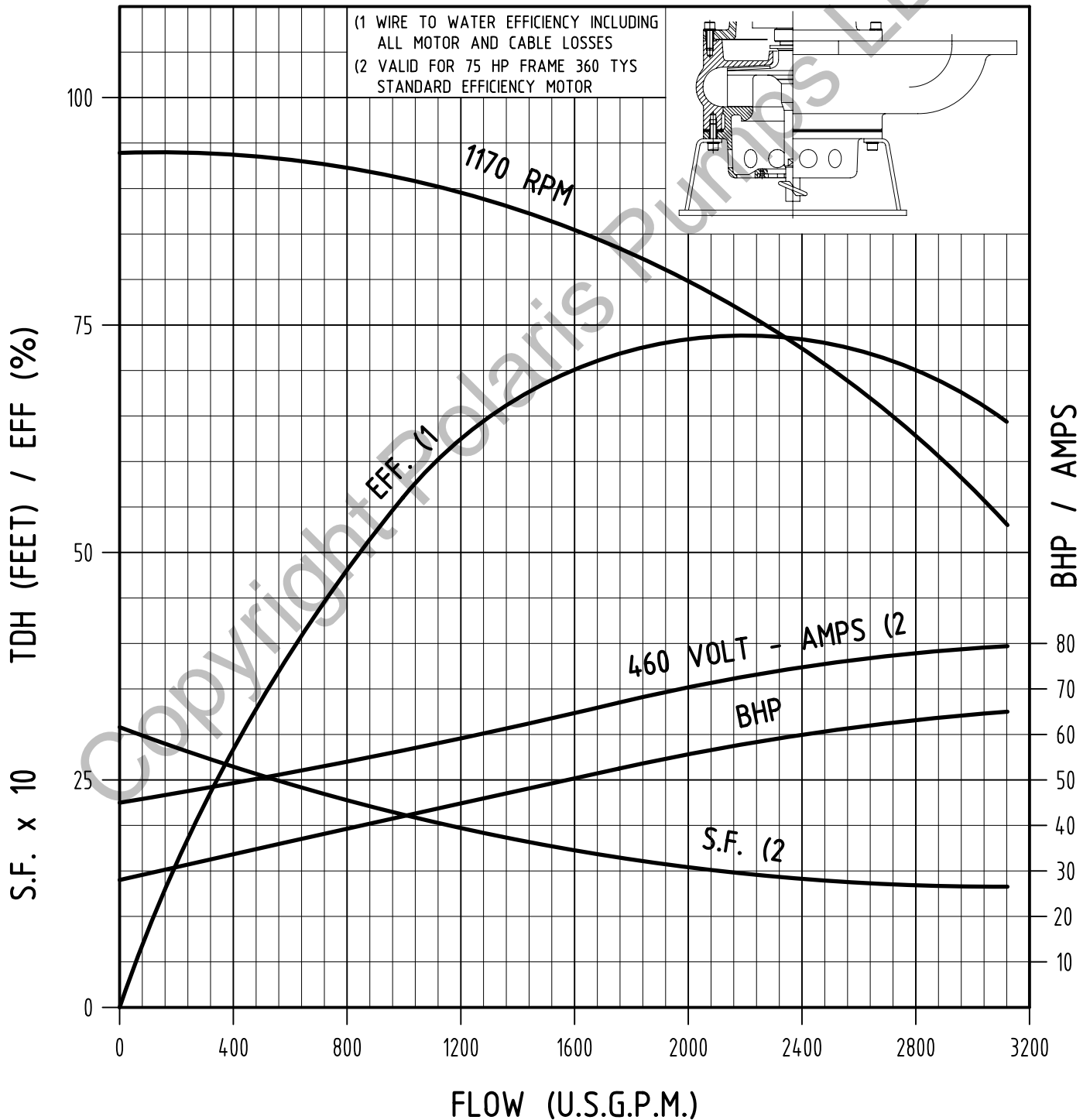

POLARIS

PUMPS

PUMP MODEL TBM 200 LH-PVO	CURVE NBR.: A0215	DISCHARGE ϕ (In) : 8	NUMBER OF VANES : 5
	REVISION : 2	IMPELLER ϕ (In) : 14.76	FRAME REF. : 320TY-360TYS
	TEST NBR.: TBM200LH-PB0-001	MAX. SOLIDS ϕ (In) : 1.58	FREQUENCY : 60 Hz
	EFFECTIVE DATE : 04-04-02	PERFORMANCE FOR <u>CLEAR WATER</u> @ 68°F/20°C AND 1.0 S.G. CORRECT FOR OTHER CONDITIONS AND/OR SOLIDS EFFECT	
	APPROVED BY : UJB		

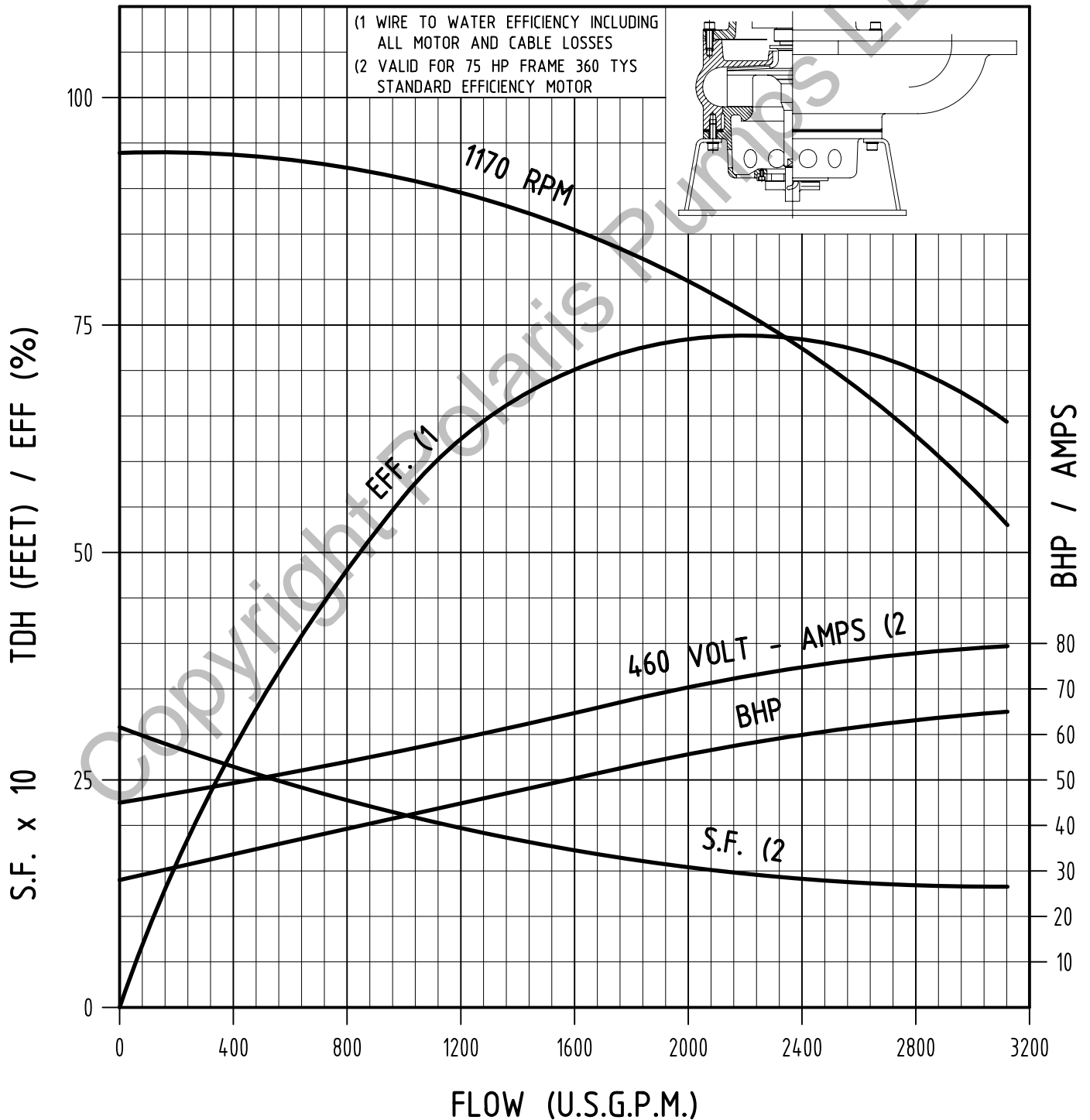

BALDOR • RELIANCE



AC Submersible Pump Motors

Copyright Polaris Pumps LLC

Installation & Operating Manual

Any trademarks used in this manual are the property of their respective owners.

Copyright Polaris Pumps LLC

Table of Contents

Section 1

General Information	1-1
Overview	1-1
Limited Warranty	1-1
Safety Notice	1-1
Receiving	1-2
Handling	1-2

Section 2

Installation & Operation	2-1
Overview	2-1
Installation	2-2
Grounding	2-3
Operation	2-6

Copyright Polaris Pumps LLC

Copyright Polaris Pumps LLC

Section 1

General Information

Overview This manual contains general procedures that apply to Baldor•Reliance Motor products. Be sure to read and understand the Safety Notice statements in this manual. For your protection, do not install, operate or attempt to perform maintenance procedures until you understand the **Warning and Caution** statements.

A **Warning** statement indicates a possible unsafe condition that can cause harm to personnel.
A **Caution** statement indicates a condition that can cause damage to equipment.

Important: **This instruction manual is not intended to include a comprehensive listing of all details for all procedures required for installation, operation and maintenance. This manual describes general guidelines that apply to most of the motor products. If you have a question about a procedure or are uncertain about any detail, Do Not Proceed. Please contact your Baldor District Office for more information or clarification.**

Before you install, operate or perform maintenance, become familiar with the following:

- NEMA Publication MG-2, Safety Standard for Construction and guide for Selection, Installation and Use of Electric Motors and Generators.
- The National Electrical Code
- Local codes and Practices

Limited Warranty

www.baldor.com/support/warranty_standard.asp

Safety Notice: This equipment contains high voltage! Electrical shock can cause serious or fatal injury. Only qualified personnel should attempt installation, operation and maintenance of electrical equipment.

Be sure that you are completely familiar with NEMA publication MG-2, safety standards for construction and guide for selection, installation and use of electric motors and generators, the National Electrical Code and local codes and practices. Unsafe installation or use can cause conditions that lead to serious or fatal injury. Only qualified personnel should attempt the installation, operation and maintenance of this equipment.

WARNING: **The Adjustable Speed Controller may apply hazardous voltages to the motor leads after power to the controller has been turned off. Verify that the controller is incapable of delivering hazardous voltages and that the voltage at the motor leads is zero before proceeding. Failure to observe this precaution may result in severe bodily injury or death.**

WARNING: **Do not touch electrical connections before you first ensure that power has been disconnected. Electrical shock can cause serious or fatal injury. Only qualified personnel should attempt the installation, operation and maintenance of this equipment.**

WARNING: **Be sure the system is properly grounded before applying power. Do not apply AC power before you ensure that all grounding instructions have been followed. Electrical shock can cause serious or fatal injury. National Electrical Code and Local codes must be carefully followed.**

WARNING: **Avoid extended exposure to machinery with high noise levels. Be sure to wear ear protective devices to reduce harmful effects to your hearing.**

WARNING: **Surface temperatures of motor enclosures may reach temperatures which can cause discomfort or injury to personnel accidentally coming into contact with hot surfaces. Protection should be provided by the user to protect against accidental contact with hot surfaces. Failure to observe this precaution could result in bodily injury.**

WARNING: **This equipment may be connected to other machinery that has rotating parts or parts that are driven by this equipment. Improper use can cause serious or fatal injury. Only qualified personnel should attempt to install operate or maintain this equipment.**

WARNING: **Do not by-pass or disable protective devices or safety guards. Safety features are designed to prevent damage to personnel or equipment. These devices can only provide protection if they remain operative.**

WARNING: **Avoid the use of automatic reset devices if the automatic restarting of equipment can be hazardous to personnel or equipment.**

WARNING: **Be sure the load is properly coupled to the motor shaft before applying power. The shaft key must be fully captive by the load device. Improper coupling can cause harm to personnel or equipment if the load decouples from the shaft during operation.**

WARNING: **Use proper care and procedures that are safe during handling, lifting, installing, operating and maintaining operations. Improper methods may cause muscle strain or other harm.**

Safety Notice Continued

- WARNING:** Pacemaker danger – Magnetic and electromagnetic fields in the vicinity of current carrying conductors and permanent magnet motors can result in a serious health hazard to persons with cardiac pacemakers, metal implants, and hearing aids. To avoid risk, stay away from the area surrounding a permanent magnet motor.
- WARNING:** Incorrect motor rotation direction can cause serious or fatal injury or equipment damage. Be sure to verify motor rotation direction before coupling the load to the motor shaft.
- WARNING:** Do not use non UL/CSA listed explosion proof motors in the presence of flammable or combustible vapors or dust. These motors are not designed for atmospheric conditions that require explosion proof operation.
- WARNING:** Motors that are to be used in flammable and/or explosive atmospheres must display the UL label on the nameplate along with CSA listed logo. Specific service conditions for these motors are defined in NFPA 70 (NEC) Article 500.
- WARNING:** UL Listed motors must only be serviced by UL Approved Authorized Baldor Service Centers if these motors are to be returned to a hazardous and/or explosive atmosphere.
- WARNING:** Thermostat contacts automatically reset when the motor has slightly cooled down. To prevent injury or damage, the control circuit should be designed so that automatic starting of the motor is not possible when the thermostat resets.
- Caution:** To prevent equipment damage, be sure that the electrical service is not capable of delivering more than the maximum motor rated amps listed on the rating plate.
- Caution:** If a HI POT test (High Potential Insulation test) must be performed, follow the precautions and procedure in NEMA MG1 and MG2 standards to avoid equipment damage.
- Caution:** Never raise or lower the motor/pump by the power cords. Use lifting eyes provided in the motor casting (opposite drive end) and attach a cord/cable to lift the weight of the motor and pump. Failure to lift this motor properly may seriously damage the lead connections and water seals and seriously damage the motor.

If you have any questions or are uncertain about any statement or procedure, or if you require additional information please contact your Baldor District Office or an Authorized Baldor Service Center.

Receiving

Each Baldor•Reliance Motor is thoroughly tested at the factory and carefully packaged for shipment. When you receive your motor, there are several things you should do immediately.

1. Observe the condition of the shipping container and report any damage immediately to the commercial carrier that delivered your motor.
2. Verify that the part number of the motor you received is the same as the part number listed on your purchase order.

Handling

The motor must be stored shaft down in its' original packaging until it is to be into service. The motor should only be lifted using the lifting eyes provided, see Figure 2-1.

- Caution:** Never raise or lower the motor/pump by the power cords. Use lifting eyes provided in the motor casting (opposite drive end) and attach a cord/cable to lift the weight of the motor and pump. Failure to lift this motor properly may seriously damage the lead connections and water seals and seriously damage the motor.
1. Only use the lifting eyes provided to lift the motor. Never attempt to lift the motor by the power cords.
 2. Be sure the motor is stored shaft down until ready to install.

Section 2 Installation & Operation

Overview

Installation should conform to the National Electrical Code as well as local codes and practices. All Baldor•Reliance Submersible Pump Motors Include thermal devices as standard. Normally, there are four conditions during which a submersible sewage pump may be operated in gases or vapors.

1. When the wet well is being dewatered.
2. When the pump motor assembly is being lowered down the guide rails.
The flow from the pump is needed during the installation process to ensure that solids are cleared from the discharge flange area to ensure proper seating.
3. When low-level cutoff controls fail.
4. When low-level sensors are positioned at the bottom of the pump assembly.

Continuous Operation Gasses Or Vapors

Be sure you have selected the correct motor for your application. The horsepower rating of the motor is determined by the pump design, impeller size & head and flow conditions.

Operating time is a function of pit size, pump capacity, and flow conditions. Only the pump manufacturer can ensure that the pump motor is properly applied for continuous in-gas or vapor operation. As with any motor product, it is essential that proper consideration be given to the load characteristics to ensure the motor will not be overloaded. Should such an overload occur, thermostats embedded in the windings will provide a signal to deenergize the motor. However, proper consideration of the application will prevent such an overload.

Caution: Lift using Lift Eyes only. Lifting by power cords will cause motor damage. Use spreader bar to evenly distribute lift force. Angle of lift rope (no spreader bar) should not exceed 45° from vertical, excessive lift angle can damage motor.

Figure 2-1

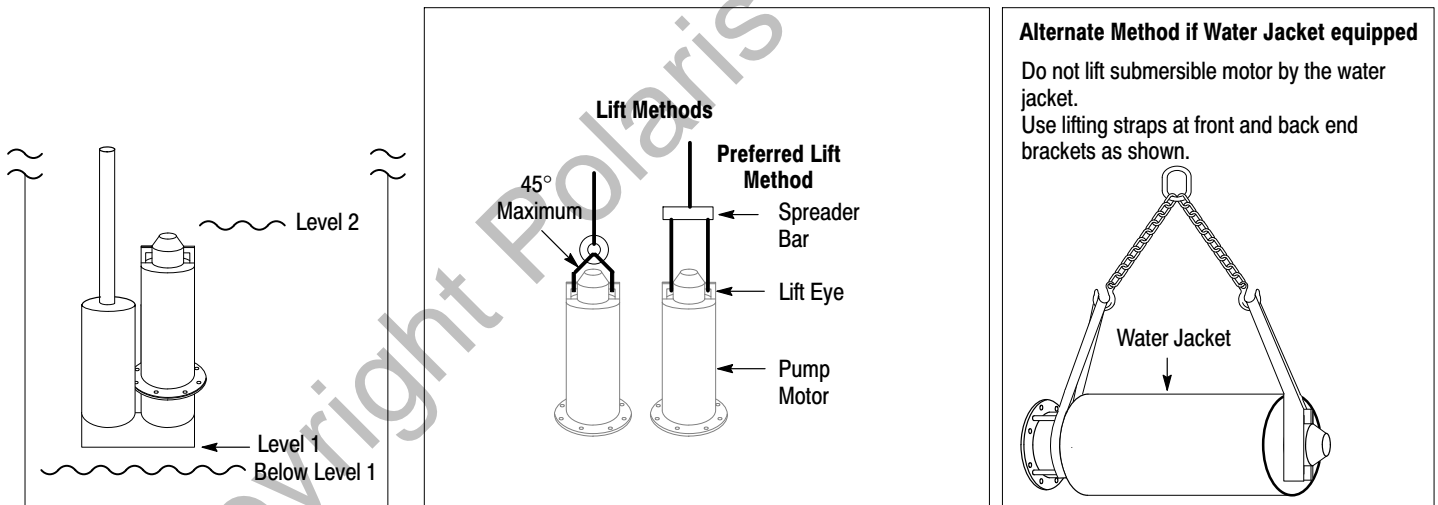

The following load conditions should be noted, refer to Figure 2-1:

1. Below Level 1 (below the pump) fluid is not pumped and no load is reflected to the motor.
2. One pump should always be sized sufficiently large to draw the well down (even under maximum flow conditions). The maximum amount of time the motor will operate fully loaded and uncovered is the amount of time required to draw the well down from Level 2 (top of the motor) to the bottom of the pump.
3. Time described in 2 should not be greater than 15 minutes.
4. These notes do not make allowance for the following:
 - a. The heat exchanger effect of the attached pump. It is pumping a relatively cool fluid and will remove some heat.
 - b. The motor does not operate fully loaded completely in gas. It is fully loaded as the motor is being uncovered.
 - c. If the well is being drawn down from the top of the motor and the maximum flow conditions exist, the influent flow will usually provide excellent cooling of the pump motor.

WARNING: Do not touch electrical connections before you first ensure that power has been disconnected. Electrical shock can cause serious or fatal injury. Only qualified personnel should attempt the installation, operation and maintenance of this equipment.

WARNING: The Adjustable Speed Controller may apply hazardous voltages to the motor leads after power to the controller has been turned off. Verify that the controller is incapable of delivering hazardous voltages and that the voltage at the motor leads is zero before proceeding. Failure to observe this precaution may result in severe bodily injury or death.

Installation When the submersible pump motor leaves the factory it is ready for installation. No adjustment, venting or oil filling is required.

Considerations

1. The user must select a motor starter and over-current protection suitable for this motor and its application. Consult motor starter application data as well as the National Electric Code and/or other local codes.
2. Maximum submergence of motor is not to exceed 160 ft (49m) in depth and or 100 PSI (690 kpas) at the external motor seal for Tandem Seal designs. For slurry seal designs the maximum external motor seal pressure is 15 PSI (103 kpas).
3. Thermal Protectors must be connected. Leads marked P1 and P2 (See Figure 2-2).
4. Moisture Sensing Probes must be connected. Leads marked W1 and W2. (See Figure 2-3).
5. Check your power supply against final nameplate connection voltage.
6. Motor will operate properly with frequency not more than $\pm 5\%$ and voltage not more than $\pm 10\%$ above or below nameplate rating.
7. Performance within this range will not necessarily be the same as the established performance at exact rated voltage and frequency.
8. For three phase motors only: To reverse direction of a three phase motor, interchange any two motor lead connections at the starter.

Installation Procedure

To prevent damage to the motor, do not use force to drive pump on (drive impeller onto motor shaft) or to remove pump from motor shaft.

1. Turn off and lockout all power and verify the voltage at the motor starter connectors are zero.
2. Connect the motor power leads to the connectors in the motor starter. (See "Grounding").

Note: The motor lead cable assembly for all Submersible Pump Motors has 3 marked power leads plus two ground leads, two thermal leads and two moisture sensing probe leads.

3. **Three Phase Motors ONLY.**
 - a. Turn off and lockout all power and verify the voltage at the motor starter connectors are zero.
 - b. Be sure the motor shaft is disconnected from the load and will not cause mechanical rotation of the motor shaft.
 - c. Remove all unused shaft keys and loose rotating parts to prevent them from flying off.
 - d. Momentarily apply power and check the direction of rotation of the motor shaft.
Motors are designed for bi-directional shaft rotation. When voltages in an A-B-C phase sequence are applied to leads U/T1, V/T2, W/T3 clockwise shaft rotation facing the opposite drive end will result. If shaft rotation is incorrect, change the direction of rotation as follows:
 - i. Turn off and lockout all power and verify that the voltage at the motor leads is zero.
 - ii. Reverse any two of three motor power leads at the motor starter.
 - iii. Restore power and verify correct rotation.
 - iv. Turn off and lockout all power and verify that the voltage at the motor leads is zero.
4. Connect the two Thermal Protectors at the motor starter as shown in Figure 2-2.
5. Connect the two Moisture Sensing Probes at the motor starter as shown in Figure 2-3.
6. Follow pump manufacturer's instructions and mount the pump on the motor shaft.
7. Secure the pump case to the motor flange.
8. Attach drain piping to pump.
9. Use spreader bar and lifting eyes (see Figure 2-1) to lower the motor/pump assembly to the proper depth. Be sure that motor wires are not damaged (contact with metal objects etc.)
10. Set control parameter values (if applicable) according to motor nameplate values.

Grounding In the USA consult the National Electrical Code, Article 430 for information on grounding of motors and generators, and Article 250 for general information on grounding. In making the ground connection, the installer should make certain that there is a solid and permanent metallic connection between the ground point, the motor or generator terminal housing, and the motor or generator frame. In non-USA locations consult the appropriate national or local code applicable.

Motors with resilient cushion rings usually must be provided with a bonding conductor across the resilient member. Some motors are supplied with the bonding conductor on the concealed side of the cushion ring to protect the bond from damage. Motors with bonded cushion rings should usually be grounded at the time of installation in accordance with the above recommendations for making ground connections. When motors with bonded cushion rings are used in multimotor installations employing group fusing or group protection, the bonding of the cushion ring should be checked to determine that it is adequate for the rating of the branch circuit over current protective device being used.

There are applications where grounding the exterior parts of a motor or generator may result in greater hazard by increasing the possibility of a person in the area simultaneously contacting ground and some other nearby live electrical parts of other ungrounded electrical equipment. In portable equipment it is difficult to be sure that a positive ground connection is maintained as the equipment is moved, and providing a grounding conductor may lead to a false sense of security.

Select a motor starter and over current protection suitable for this motor and its application. Consult motor starter application data as well as the National Electric Code and/or other applicable local codes.

Adjustable Frequency Power Inverters used to supply adjustable frequency power to induction motors produce wave forms with lower order harmonics with voltage spikes superimposed. Turn-to-turn, phase-to-phase, and ground insulation of stator windings are subject to the resulting dielectric stresses. Suitable precautions should be taken in the design of these drive systems to minimize the magnitude of these voltage spikes. Consult the drive instructions for maximum acceptable motor lead lengths, and proper grounding.

Thermal Protection

Thermostat leads marked P1 & P2 must be connected in series with the stop button of the 3-wire pilot circuit of the magnetic motor controller, so that the thermostat will open the circuit before dangerous temperatures are reached. Thermostats are automatic reset for use in a normally closed circuit where the thermostat is connected in series with the holding coil of the magnetic starter. Thermostats provide "Over Temperature" Protection in accordance with NEMA MG 1-12.53. Thermostats do not provide winding over temperature protection (locked rotor). It is suggested that over current protection be used in the motor starter to ensure locked rotor protection.

Figure 2-2 Thermal Protection Circuit

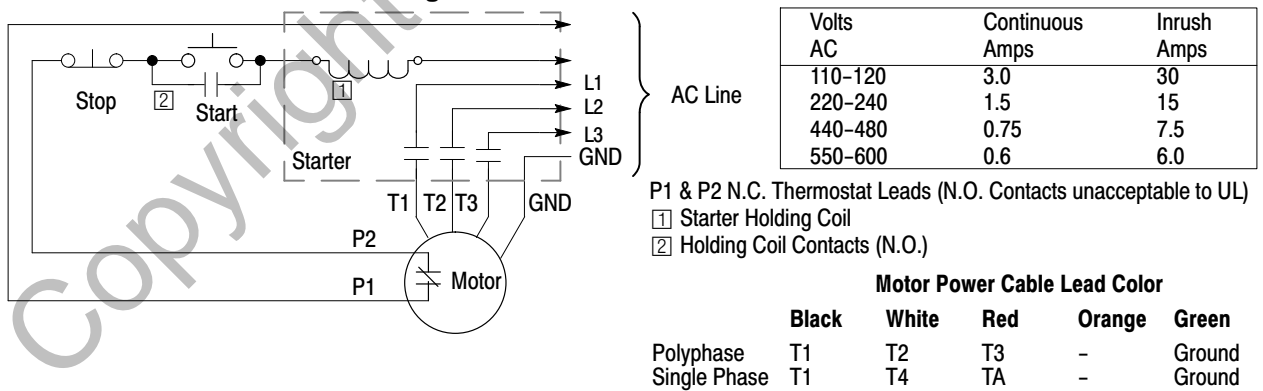

Moisture Protection

The submersible moisture protection system consists of the non-wicking cable cap assembly and the dual moisture sensing probes. The cable cap assembly prevents moisture from wicking through the cable assembly even when the cable jacket has been punctured.

Dual moisture sensing probes (Warrick type) extend into the oil chamber located between the tandem mechanical seals. Should the outer seal fail, water will enter the oil chamber through the labyrinth slinger paths and create a water/oil emulsion in the oil chamber. The moisture detector control applies 500 volts to the moisture probes.

The presence of water in the oil chamber increases the conductivity sufficiently to increase current flow through the probe circuit which illuminates a warning light and activates a relay to de-energize the motor. The leakage detector control must be purchased separately from Charles F. Warrick Co. Normandy Ct. Royal Oak, MI 48073 (810) 549-4900.

The leakage detector control system must be connected for the warranty and the U/L listing to be valid. For information on the relay, see www.gemssensors.com (look for Model 2800/2810 relay). It's circuit diagram is shown in Figure 2-3.

Figure 2-3 Moisture Sensing Circuit

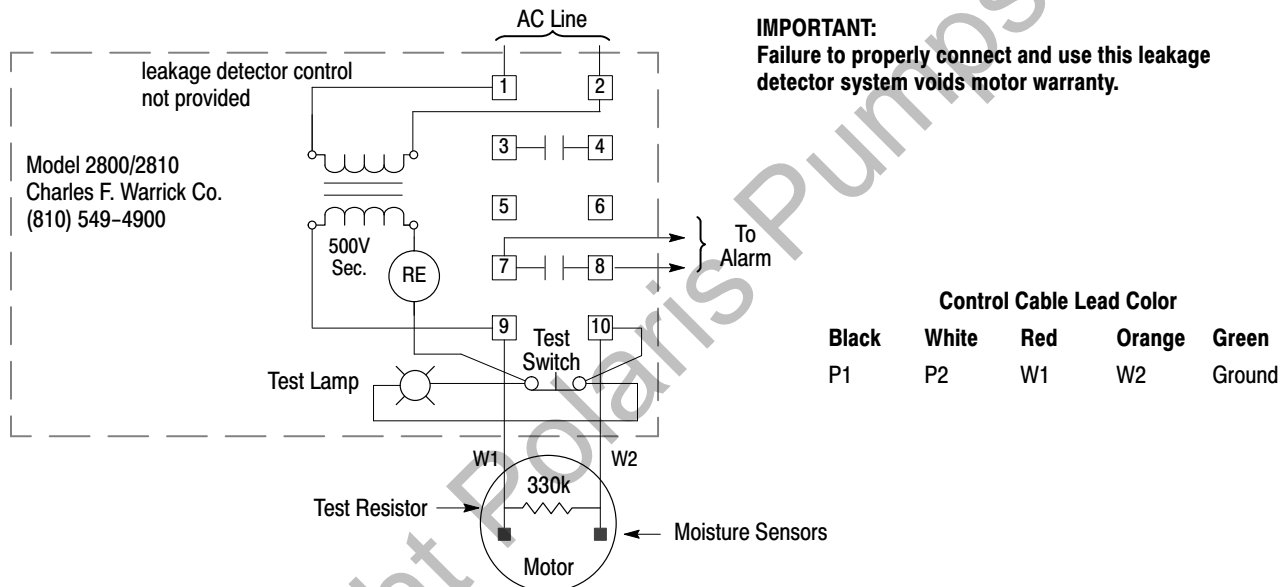

ORDER BY COMPONENT NUMBER ----- *-2800-XXX

AC SUPPLY LINE VOLTAGE & FREQUENCY	
1	115V 50/60 Hz
2	230V 50/60Hz
4	480V 50/60Hz

Line voltage are nominal values and may range from nominal minus 15% to nominal plus 10%.

	CONTACT CONFIGURATION		
	TERMINAL PAIR		
	3-4	5-6	7 8
A	•	N.O.	•
B	•	N.C.	•
C	N.O.	•	N.O.
D	N.C.	•	N.O.
E	N.C.	•	N.C.
F	N.O.	N.O.	N.O.
G	N.C.	N.O.	N.O.
H	N.C.	N.C.	N.O.
J	N.C.	N.C.	N.C.
N.O.	NORMALLY OPEN		
N.C.	NORMALLY CLOSED		
•	NONE PROVIDED		

NEMA TYPE ENCLOSURE	
1	1
4	2, 4, 6

Installation (for reference only)

Note: Since changes occur, always refer to installation and connection documentation from the manufacturer and follow their procedures.

All type 2800-XXX controls are identified by a specific component number which follows the format 2800-XXX where the X's are replaced by numbers and letters indicative of the A-C supply line voltage and frequency, contact configuration and enclosure. Each control has a data label on the right hand side of the terminal block. In addition, each enclosed control has another data label on the outside of the enclosure cover.

Mount the control on a vertical surface with the transformer on the left hand side and accomplish all indicated wiring. Terminals on the control are numbered and are in the same relative position as the terminals shown on the wiring diagram.

Terminal pair 1 -2 must be continuously energized from an A-C supply line of electrical characteristics shown on the data label. Contacts must be wired into the electrical load circuit(s) of the warning devices as required. Each contact used for load duty must be wired in series with the load and that series branch circuit connected across a power source compatible with the load.

Wiring must be provided from the moisture detector sensor probe leads W1 and W2 to terminals 9 and 10 of the 2800-XXX control. Control leads should not be installed in the same conduit as power leads. Induced voltage can cause false moisture signals.

Contact Operation

Normally open load contacts close and normally closed load contacts open when the sensor probes detect the influx of moisture within the motor.

Test Procedure

A normally closed pushbutton and neon indicating lamp are provided as means of checking the moisture sensing components. When the pushbutton is depressed, the indicating lamp will be illuminated to indicate (A) power is supplied to the control, (B) the control is operative, and (C) wiring to the moisture sensing probes in the motor is intact. This procedure should be performed periodically to confirm integrity of circuit. Signal devices The signal device may be audible (bell, buzzer, horn or siren) or visible (incandescent or neon lamp) or both - a signal device of your choice may be obtained from your local electrical supply house.

Signal Devices

The signal device may be audible (bell, buzzer, horn or siren) or visible (incandescent or neon lamp) or both - a signal device of your choice may be obtained from your local electrical supply house.

System Operation

It is recommended that upon indication (by warning light, etc.,) of outer seal failure that the motor be removed from the installation and the oil and outer seal be replaced as soon as possible. If reconditioning is not performed within a 30 day period it is recommended that the inner seal be thoroughly inspected and replaced if required.

WARNING: Surface temperatures of motor enclosures may reach temperatures which can cause discomfort or injury to personnel accidentally coming into contact with hot surfaces. Protection should be provided by the user to protect against accidental contact with hot surfaces. Failure to observe this precaution could result in bodily injury.

WARNING: Do not touch electrical connections before you first ensure that power has been disconnected. Electrical shock can cause serious or fatal injury. Only qualified personnel should attempt the installation, operation and maintenance of this equipment.

WARNING: Disconnect all electrical power from the motor windings and accessory devices before disassembly of the motor. Electrical shock can cause serious or fatal injury.

WARNING: Be sure the system is properly grounded before applying power. Do not apply AC power before you ensure that all grounding instructions have been followed. Electrical shock can cause serious or fatal injury. National Electrical Code and Local codes must be carefully followed.

Operation

During operation, observe the motors performance. It should run smoothly with little noise. Motor operation may stop for one of the following trip conditions:

1. If moisture infiltrates the motor, the moisture detector circuit will activate.
2. If the motor overheats, the Thermal Protection circuit will activate.
3. Other condition detected by motor starter (over current, overvoltage, etc. if equipped)

Unbalanced voltage or single-phase operation of poly phase motor may cause excessive heating and ultimate failure. Only a slight unbalance of voltage applied to a poly phase motor will cause large unbalanced currents and resultant overheating. Periodic checks of phase voltage, frequency and power consumption of a motor (measured at the motor starter) while in operation are recommended; such checks assure the correctness of frequency and voltage applied to the motor and yield an indication of the load offered by the apparatus which the motor drives.

Comparisons of this data with previous no load and full-load power demands will give an indication of the performance of the complete machine. Any serious deviations should be investigated and corrected.

If a problem with the motor occurs, contact your Baldor District Office for repair.

Should the lead connector assembly be damaged or the integrity of the encapsulation be in question, it is required that a replacement lead connector assembly be ordered from Baldor, contact your Baldor District Office. Renewal instructions will be provided with the replacement parts.

Baldor District Offices

UNITED STATES

ARIZONA

PHOENIX
4211 S 43RD PLACE
PHOENIX, AZ 85040
PHONE: 602-470-0407
FAX: 602-470-0464

ARKANSAS

CLARKSVILLE
1001 COLLEGE AVE.
CLARKSVILLE, AR 72830
PHONE: 479-754-9108
FAX: 479-754-9205

CALIFORNIA

LOS ANGELES
6480 FLOTILLA
COMMERCE, CA 90040
PHONE: 323-724-6771
FAX: 323-721-5859

HAYWARD
21056 FORBES STREET
HAYWARD, CA 94545
PHONE: 510-785-9900
FAX: 510-785-9910

COLORADO

DENVER
3855 ForestStreet
Denver, CO 80207
PHONE: 303-623-0127
FAX: 303-595-3772

CONNECTICUT

WALLINGFORD
65 SOUTH TURNPIKE ROAD
WALLINGFORD, CT 06492
PHONE: 203-269-1354
FAX: 203-269-5485

FLORIDA

**TAMPA/PUERTO RICO/
VIRGIN ISLANDS**
3906 EAST 11TH AVENUE
TAMPA, FL 33605
PHONE: 813-248-5078
FAX: 813-247-2984

GEORGIA

ATLANTA
62 TECHNOLOGY DR.
ALPHARETTA, GA 30005
PHONE: 770-772-7000
FAX: 770-772-7200

ILLINOIS

CHICAGO
4 SAMMONS COURT
BOLINGBROOK, IL 60440
PHONE: 630-296-1400
FAX: 630-226-9420

INDIANA

INDIANAPOLIS
5525 W. MINNESOTA STREET
INDIANAPOLIS, IN 46241
PHONE: 317-246-5100
FAX: 317-246-5110

IOWA

DES MOINES
1800 DIXON STREET, SUITE C
DES MOINES, IA 50316
PHONE: 515-263-6929
FAX: 515-263-6515

MARYLAND

BALTIMORE
8660 SANTA BARBARA RD.
SUITE 22-24
ELKRIDGE, MD 21075
PHONE: 410-579-2135
FAX: 410-579-2677

MASSACHUSETTS

BOSTON
6 PULLMAN STREET
WORCESTER, MA 01606
PHONE: 508-854-0708
FAX: 508-854-0291

MICHIGAN

DETROIT
5993 ProgressDrive
STERLING HEIGHTS, MI 48312
PHONE: 586-978-9800
FAX: 586-978-9969

MINNESOTA

MINNEAPOLIS
21080 134TH AVE. NORTH
ROGERS, MN 55374
PHONE: 763-428-3633
FAX: 763-428-4551

MISSOURI

ST LOUIS
422 INDUSTRIAL DRIVE
MARYLAND HEIGHTS, MO 63043
PHONE: 314-298-1800
FAX: 314-298-7660

KANSAS CITY

1501 BEDFORD AVENUE
NORTH KANSAS CITY, MO 64116
PHONE: 816-587-0272
FAX: 816-587-3735

NEW YORK

AUBURN
ONE ELLIS DRIVE
AUBURN, NY 13021
PHONE: 315-255-3403
FAX: 315-253-9923

NORTH CAROLINA

GREENSBORO
1220 ROTHERWOOD ROAD
GREENSBORO, NC 27406
PHONE: 336-272-6104
FAX: 336-273-6628

OHIO

CINCINNATI
2929 CRESCENTVILLE ROAD
WEST CHESTER, OH 45069
PHONE: 513-771-2600
FAX: 513-772-2219

CLEVELAND

8929 FREEWAY DRIVE
MACEDONIA, OH 44056
PHONE: 330-468-4777
FAX: 330-468-4778

OKLAHOMA

TULSA
7170 S. Braden, Suite140
Tulsa, OK 74136
PHONE: 918-366-9320
FAX: 918-366-9338

OREGON

PORTLAND
20393 SW AVERY COURT
TUALATIN, OR 97062
PHONE: 503-691-9010
FAX: 503-691-9012

PENNSYLVANIA

PHILADELPHIA
1035 THOMAS BUSCH
MEMORIAL HIGHWAY
PENNSAUKEN, NJ 08110
PHONE: 856-661-1442
FAX: 856-663-6363

PITTSBURGH

159 PROMINENCE DRIVE
NEW KENSINGTON, PA 15068
PHONE: 724-899-0092
FAX: 724-899-0094

TENNESSEE

MEMPHIS
4000 WINCHESTER ROAD
MEMPHIS, TN 38118
PHONE: 901-365-2020
FAX: 901-365-3914

TEXAS

DALLAS
3040 QUEBEC
DALLAS, TX 75247
PHONE: 214-634-7271
FAX: 214-634-8874

HOUSTON

10355 W. LittleYorkRd.
Suite300
Houston, TX 77041
PHONE: (281) 977-6500
FAX: (281) 977-6510

UTAH

SALT LAKE CITY
2230 SOUTH MAIN STREET
SALT LAKE CITY, UT 84115
PHONE: 801-832-0127
FAX: 801-832-8911

WISCONSIN

MILWAUKEE
2725 SOUTH 163RD STREET
NEW BERLIN, WI 53151
PHONE: 262-784-5940
FAX: 262-784-1215

INTERNATIONAL SALES

FORT SMITH, AR
P.O. BOX 2400
FORT SMITH, AR 72902
PHONE: 479-646-4711
FAX: 479-648-5895

CANADA

EDMONTON, ALBERTA
4053-92 STREET
EDMONTON, ALBERTA T6E 6R6
PHONE: 780-434-4900
FAX: 780-438-2600

TORONTO

OAKVILLE, ONTARIO
2750 COVENTRY ROAD
OAKVILLE, ONTARIO L6H 6R1
PHONE: 905-829-3301
FAX: 905-829-3302

MONTREAL, QUEBEC

5155, J.A. Bombardier
St-Hubert(Quebec) Canada
J3Z 1G4
PHONE: 514-933-2711
FAX: 514-933-8639

VANCOUVER,

BRITISH COLUMBIA
1538 KEBET WAY
PORT COQUITLAM,
BRITISH COLUMBIA V3C 5M5
PHONE: 604-421-2822
FAX: 604-421-3113

WINNIPEG, MANITOBA

54 PRINCESS STREET
WINNIPEG, MANITOBA R3B 1K2
PHONE: 204-942-5205
FAX: 204-956-4251

AUSTRALIA

UNIT 3, 6 STANTON ROAD
SEVEN HILLS, NSW 2147,
AUSTRALIA
PHONE: (61) (2) 9674 5455
FAX: (61) (2) 9674 2495
UNIT 8, 5 KELLETTS ROAD
ROWVILLE, VICTORIA, 3178
AUSTRALIA
PHONE: (61) (3) 9753 4355
FAX: (61) (3) 9753 4366

ELSALVADOR

RESIDENCIAL PINARES DE SUIZA
POL. 15 #44,
NVA. SAN SALVADOR,
EL SALVADOR
PHONE: +503 2288-1519
FAX: +503 2288-1518

CHILE

LuisThayerOjeda166,
of402 - Providencia
Santiago, Chile
Phone: +56 2 816 9900

CHINA

160 SongSHENG road
SongjiangINDUSTRY ZONE
Shanghai201613, China
PHONE: +86 21 5760 5335
FAX: +86 21 5760 5336

GERMANY

DIESELSTRASSE 22
D-85561 KIRCHHEIM
MUNICH, GERMANY
PHONE: +49 89 90 6080
FAX: +49 89 90 50 8492

INDIA

14, COMMERCE AVENUE
MAHAGANESH COLONY
PAUD ROAD
PUNE - 411038
MAHARASHTRA, INDIA
PHONE: +91 20 25 45 27 17 / 18
FAX: +91 20 25 45 27 19

ITALY

BaldorASR AG
SUCCURSALE DI Mendrisio
ViaBorromini, 20A
CH-6850 Mendrisio
Switzerland
PHONE: 0041 91 640 99 50
FAX: 0041 91 630 26 33

JAPAN

DIA BLDG 802,
2-21-1 TSURUYA-CHO,
KANAGAWA-KU
YOKOHAMA, 221-0835, JAPAN
PHONE: 81-45-412-4506
FAX: 81-45-412-4507

MEXICO

LEON, guanajuato
KM. 2.0 BLVD. AEROPUERTO
LEON 37545, GUANAJUATO,
MÉXICO
PHONE: +52 477 761 2030
FAX: +52 477 761 2010

MIDDLE EAST & NORTH AFRICA

VSE INTERNATIONAL CORP.
P. O. BOX 5618
BUFFALO GROVE, IL 60089-5618
PHONE: 847 590 5547
FAX: 847 590 5587

PANAMA

AVE. RICARDO J. ALFARO
EDIFICIO SUN TOWERS MALL
PISO 2, LOCAL 55
CiudaddePanamá, Panamá
PHONE: +507 236-5155
FAX: +507 236-0591

SINGAPORE

18 KAKI BUKIT ROAD 3, #03-09
ENTREPRENEUR BUSINESS
CENTRE SINGAPORE 415978
PHONE: (65) 6744 2572
FAX: (65) 6747 1708

SWITZERLAND

POSTFACH 73
SCHUTZENSTRASSE 59
CH-8245 FEUERTHALEN
SWITZERLAND
PHONE: +41 52 647 4700
FAX: +41 52 659 2394

TAIWAN

1F, No126 Wenshan3rdStreet,
NantunDistrict,
TaichungCity408
TaiwanR.O.C
PHONE: (886) 4 238 04235
FAX: (886) 4 238 04463

UNITED KINGDOM

6 BRISTOL DISTRIBUTION PARK
HAWKLEY DRIVE
BRISTOL BS32 0BF U.K.
PHONE: +44 1454 850000
FAX: +44 1454 859001

VENEZUELA

Av. Roma, QtaelMiliagro. Urb.
CaliforniaNorte
Caracas, 1070
Venezuela
Phone/fax: +58 212 272 7343
mobile: +58 414 114 8623



Copyright Polaris Pumps LLC



BALDOR ELECTRIC COMPANY
World Headquarters
P.O. Box 2400 Fort Smith, AR 72901-2400
(479) 646-4711 Fax (479) 648-5792
www.baldor.com

ENGINEERING STANDARD PROCEDURE				1 of 2	
IMPELLER INSTALLATION – TECH BULLETIN					
DOCUMENT NBR. :	A0431	REVISION:	3	EFFECTIVE DATE:	01-26-2012

1.0 SCOPE: The purpose of this Engineering Standard Document is to define the procedure to be followed in installing the Impeller and Impeller Lock Screw for Series TBM.

*****DO NOT REUSE OLD IMPELLER LOCK SCREWS WHEN REBUILDING PUMPS***
*****ALWAYS USE A NEW IMPELLER LOCK SCREW*******

2.0 METHOD:



2.1 – Impeller Installation

Clean and degrease all parts prior to impeller installation.

Using a grease remover or solvent, remove all grease, oil or preservative from the shaft-end internal threads and dry.

Apply Nickel based Never-Seize or similar to impeller bore, shaft and key and install impeller onto motor shaft.

DO NOT apply Never-Seize to shaft-end internal threads.



2.2 – Impeller Blocking

Position a Box / Open End wrench using one of the strainer bolts as shown. Place a wood block between the impeller and wrench.

Note: Reverse wrench location to the opposite side for impeller removal.

0		NEW	UJB		08-15-02
3		UPDATE	UJB		01-26-2012
REV	ECN	CHANGE DESCRIPTION	BY	APPV'D	DATE

ENGINEERING STANDARD PROCEDURE				2 of 2	
IMPELLER INSTALLATION – TECH BULLETIN					
DOCUMENT NBR. :	A0431	REVISION:	3	EFFECTIVE DATE:	01-26-2012



2.3 – Impeller Cap / Shaft Adapter Installation

Using a grease remover or solvent, remove all oil or grease from impeller screw. Install O-Rings onto impeller screw and impeller cap (Model PHO) or shaft adapter (Models PBO, PVO). Insert impeller screw and apply thread locker to the impeller screw and shaft-end internal threads.

Use **LOCTITE® 262** High Strength Grade or equivalent.



2.4 – Lock Screw Installation

Align and insert the impeller cap or shaft adapter into the impeller counter bore. Insert the lock screw into the motor shaft and tighten to the proper torque requirement using a calibrated torque wrench only. Confirm the torque setting by reapplying the prescribed torque 2-3 times more to compensate for initial component set.

See Table 2.5 for Torque Requirements

2.5 - Impeller Lock Screw Torque Requirements

TBM 50LH – 100LH	(1/2"-13 UNC)	55 ft/lbs (75 Nm)
TBM 150LH	(5/8"-11 UNC)	110 ft/lbs (150 Nm)
TBM 200LH	(3/4"-10 UNC)	200 ft/lbs (275 Nm)
TBM 250LH	(3/4"-10 UNC)	200 ft/lbs (275 Nm)
TBM 75MH	(5/8"-11 UNC)	110 ft/lbs (150 Nm)
TBM 100MH	(5/8"-11 UNC)	110 ft/lbs (150 Nm)
TBM 150MH	(3/4"-10 UNC)	200 ft/lbs (275 Nm)
TBM 200MH	(3/4"-10 UNC)	200 ft/lbs (275 Nm)

0		NEW	UJB		08-15-02
3		UPDATE	UJB		01-26-2012
REV	ECN	CHANGE DESCRIPTION	BY	APPV'D	DATE



P U M P S

ORIGINAL SOLUTIONS. NO COMPROMISES.

ENGINEERING STANDARD PROCEDURE FASTENER TORQUE – TECH BULLETIN				1 of 1
DOCUMENT NBR. :	A0432	REVISION:	0	EFFECTIVE DATE: 01-17-2006

1.0 SCOPE:

Assembly Pre-Load / Bolt Torque requirements for Metric Fasteners of Grades A2-70 (304L) A4-70 (316L) and 8.8, for Sizes M4 to M20.

2.0 METHOD:

ASSEMBLY TORQUE / ASSEMBLY PRE-LOAD					
SIZE	CLASS	TIGHTENING TORQUE		ASSEMBLY PRE-LOAD	
		Nm	lb/ft [lb/in]	kN	lbf
M4	A2-70, A4-70, 8.8	2.20	1.622 [19.46]	2.73	612.23
M5		4.20	3.097 [37.16]	4.47	1002.44
M6		7.40	5.45 [65.40]	6.31	1415.08
M8		17.80	13.12	11.60	2601.42
M10		36.00	26.54	18.40	4126.40
M12		62.00	45.72	26.90	6032.62
M16		150.00	110.62	50.90	11414.88
M20		303.00	223.45	82.00	18389.40

ABOVE TORQUE / PRE-LOAD VALUES ARE BASED ON A COEFFICIENT OF FRICTION OF 0.14 (Anti-seize Lubricant)

0		NEW	UJB		08-15-02
1		ADDED250LH	UJB		09-26-03
REV	ECN	CHANGE DESCRIPTION	BY	APPV'D	DATE